

Mike Pettis
310 SE Yaquina View Dr.
Newport, OR 97365
Phone (541) 961-5162

April 10, 2010

Proposal to relax fixed gear permit length restrictions

Fixed gear ground fish permits are currently restricted to being used on vessels within 5 feet in length of the vessel that originally earned the permit.

If the length restriction were relaxed to within 10 feet of the original vessel's length, it would allow vessel owners more flexibility to modify their boats to be safer and more efficient in other fisheries such as Dungeness crab. It would also provide more flexibility to vessel owners to find fixed gear ground fish permits to fit their boats. This change would not effect the amount of ground fish the fixed gear vessel would be allowed.

The west coast Dungeness crab fishery is currently the most hazardous fishery in the United States. More lives are lost per capita than in any other US fishery.

If a vessel could be made safer, better able to withstand the hazardous conditions of this fishery, it seems wrong that a permit for another fishery should hold back these modifications. This is especially true when there would be no effect to the ground fish allowed to the vessel by making these modifications.

The Dungeness crab fishery in Oregon has a one time 10 ft vessel length change allowance. A pink shrimp fisherman in Oregon can make his vessel up to 80 feet long from any original size. Would it be possible to allow a 10 ft length change instead of 5 from the original vessel to allow for needed vessel modifications ?

Vessel Modification Restrictions

Additional facts:

- 1.) Any ground fish permit can be placed on a vessel 5ft longer than the original vessels length, and then that vessel can be widened to an unlimited extent.
- 2.) On a fixed gear ground fish permit, neither vessel length, width, or horsepower affect the vessels allocation of pounds of fish, Tier limits do.
- 3.) After the original permit, two additional permits of any size can be stacked on a fixed gear vessel's permit.
- 4.) Restrictions to vessel modifications due to ground fish permits can prevent a vessel from being made SAFER and more efficient in other fisheries such as Dungeness crab which is the most hazardous fishery in the U.S.
- 5.) Relaxing the length restriction to within 10ft of the original vessel instead of 5ft on fixed gear ground fish permits would allow vessel owners more flexibility to improve their vessels without affecting the amount of fixed gear ground fish the vessel was allowed to catch.

Vessel Modification Restrictions

Vessel Beam: No restrictions.

Examples:

Original
Vessel

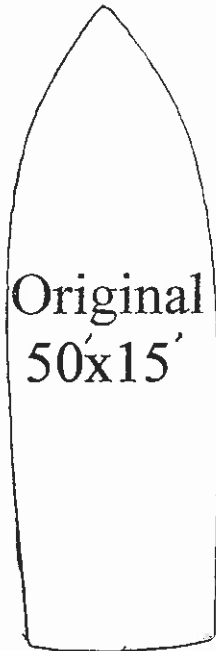

Plus
50 %

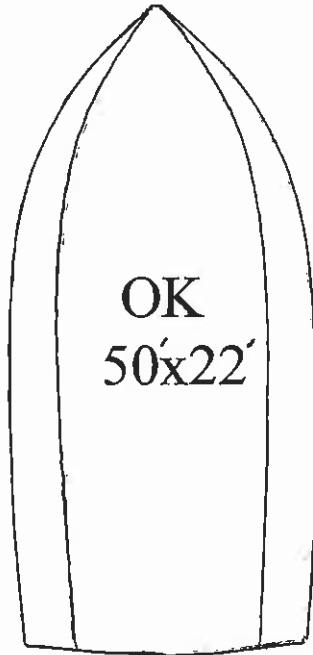

Plus
100 %

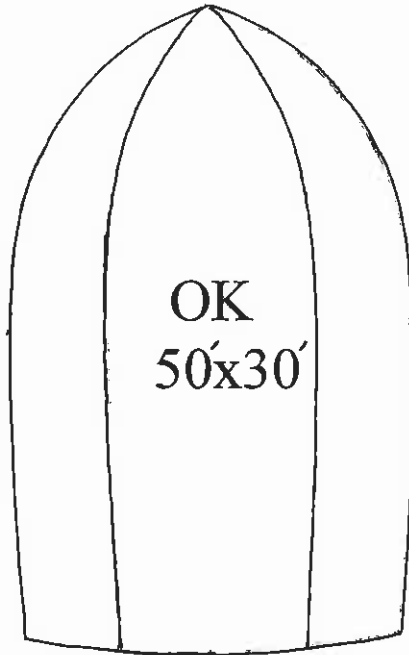

Length: 5ft restriction from original vessel.

