

Analysis for Proposed Amendment 31 to the Pacific Groundfish Fishery Management Plan in Support of the Final Preferred Alternative

Groundfish Stock Definitions, including Area Delineations, for Black Rockfish, Canary Rockfish, Copper Rockfish, Dover Sole, Lingcod, Pacific Spiny Dogfish, Petrale Sole, Quillback Rockfish, Rex Sole, Sablefish, Shortspine Thornyhead, Squarespot Rockfish, Vermilion Rockfish and Vermilion/Sunset Rockfish

June 2023

Lead Agency:	National Marine Fisheries Service, West Coast Region National Oceanic and Atmospheric Administration
Responsible Official:	Jennifer Quan, Regional Administrator West Coast Regional Office, National Marine Fisheries Service

For further information contact:

Todd Phillips
Pacific Fishery Management Council
7700 NE Ambassador Way, Suite 101
Portland, OR 97220

Gretchen Hanshew
National Marine Fisheries Service
West Coast Region
7600 Sand Point Way Northeast
Seattle, WA 98115

Analysts have consulted with NMFS West Coast Region and preliminarily determined that the proposed action may fall within one of the NOAA Categorical Exclusion categories listed in Appendix F of the Companion Manual for NOAA Administrative Order 216-6A and that none of the alternatives have the potential to have a significant effect individually or cumulatively on the human environment. This determination is subject to further review and public comment. If this determination is confirmed when a proposed rule is prepared, the proposed action will be categorically excluded from the need to prepare an Environmental Assessment.

Abstract:

The Preliminary Preferred Alternative (PPA) for Amendment 31 to the Pacific Coast Groundfish Fishery Management Plan (FMP) is analyzed in this document. Amendment 31 would define stock units, including geographic delineations within the jurisdiction of the FMP, for black rockfish, canary rockfish, copper rockfish, Dover sole, lingcod, Pacific spiny dogfish, petrale sole, quillback rockfish, rex sole, sablefish, shortspine thornyhead, squarespot rockfish, vermilion rockfish, and vermilion/sunset rockfish. The FMP at present does not include this specificity. This analysis focuses on population structure of the priority species. Population structure is a foundation to understand if a stock of a species is a single population, with a single areal delineation or if the species comprises multiple populations along its Pacific Coast range and should therefore be considered as multiple stocks in multiple, distinctly delineated, areas. The Council is considering four action alternatives under this action: Alternative 1 would define each priority species as a single stock, coastwide. Alternative 2 would define certain priority species as two stocks, specifying stocks north and south of 40° 10' N. lat. (Alternative 2) or north and south of 42° N. lat. (Sub-Alternative 2a). Alternative 3 would define certain priority species as three stocks, delineating the stocks to match state boundaries (Alternative 3) or as a Washington and Oregon stock, a northern California stock, and a southern California stock (Sub-Alternative 3a). Alternative 4 would define certain priority species as four stocks, delineating it as a Washington stock, an Oregon stock, a northern California stock and a southern California stock. The Council adopted Alternative 1 for canary rockfish, Dover sole, Pacific spiny dogfish, petrale sole, rex sole, sablefish, shortspine thornyhead, and squarespot rockfish as their PPA. The Council adopted Alternative 2 for lingcod and Alternative 2a for copper rockfish as their PPA. The Council adopted Alternative 3 for black and quillback rockfishes as their PPA. The Council did not adopt a PPA for vermilion and vermilion/sunset rockfishes. Additionally, the Council adopted two new alternatives to the range of alternatives, Alternative 2a for quillback rockfish and vermilion and vermilion/sunset rockfishes. Further, the Council is considering allowing differential harvest control rules to be used for stocks under Alternative 1 with multiple sub-area assessments (referred to as Alternative 1a), though it was not selected as part of the PPA.

Abbreviations and Acronyms

ABC	Acceptable Biological Catch	MFMT	Maximum Fishing Mortality Threshold
ACL	Annual Catch Limit	MSST	Minimum Stock Size Threshold
CE	Categorical Exclusion	MSY	Maximum Sustainable Yield
CEQ	Council On Environmental Quality	NAO	NOAA Administrative Order
CFR	Code Of Federal Regulations	NEPA	National Environmental Policy Act
Council	Pacific Fishery Management Council	NMFS	National Marine Fishery Service
E.O.	Executive Order	NOAA	National Oceanic and Atmospheric Administration
EA	Environmental Assessment	NS	National Standards
EEZ	Exclusive Economic Zone	NWFSC	Northwest Fishery Science Center
EFH	Essential Fish Habitat	OFL	Overfishing limit
EIS	Environmental Impact Statement	OY	Optimum Yield
ESA	Endangered Species Act	PPA	Preliminary Preferred Alternative
ESU	Endangered Species Unit	PRA	Paperwork Reduction Act
FMP	Fishery Management Plan	RCA	Rockfish Conservation Area
FMU	Fishery Management Unit	RFA	Regulatory Flexibility Act
FONSI	Finding Of No Significant Impact	RFFA	Reasonably Foreseeable Future Action
FR	<i>Federal Register</i>	RIR	Regulatory Impact Review
FRFA	Final Regulatory Flexibility Analysis	SAFE	Stock Assessment and Fishery Evaluation
GMT	Groundfish Management Team	SBA	Small Business Act
HCR	Harvest Control Rule	SSC	Science And Statistical Committee
IFQ	Individual Fishing Quota	Secretary	Secretary Of Commerce
IRFA	Initial Regulatory Flexibility Analysis	U.S.	United States
MSA	Magnuson-Stevens Fishery Conservation and Management Act	WCGOP	West Coast Groundfish Observer Program
MMPA	Marine Mammal Protection Act		

Contents

Executive Summary	i
ES 1 Introduction	i
ES 1.1 Purpose and Need.....	i
ES 1.2 Proposed Action.....	i
ES 1.3 Analytical Process.....	ii
ES 1.4 Alternatives.....	iii
ES 1.5 Preliminary Preferred Alternative and Range of Alternatives Modifications	iv
ES 1.6 Comparison of Alternatives.....	vi
ES 1.7 Magnuson-Stevens Act.....	vii
1. Introduction.....	1
1.1 Proposed Action.....	2
1.2 Description of Management Area.....	3
1.3 Purpose and Need	3
1.4 History of this Action.....	4
1.5 Analytical Process.....	4
2. Description of Alternatives.....	7
2.1 Summary of the Alternatives.....	7
2.1.1 Range of Alternatives.....	7
2.1.2 Council Adopted PPA and Modifications to the ROA	8
2.2 No Action	10
2.3 Alternative 1 and 1a - Single Stock	10
2.4 Alternative 2 and 2a: Two Stocks.....	11
2.5 Alternative 3 and 3a: Three Stocks.....	12
2.6 Alternative 4: Four Stocks.....	13
3. Comparison of the Alternatives	15
3.1 No Action	15
3.2 Species with Multiple Alternatives or Multiple Sub-Area Assessments	16
3.2.1 Species with Multiple Sub-area Assessments	18
3.3 Species-Specific Comparison of Alternatives	20
3.3.1 Species with only one Alternative	20
3.3.2 Canary rockfish, Dover sole, Pacific spiny dogfish, petrale sole, rex sole, sablefish, and shortspine thornyhead: PPA Analysis.....	20
3.3.3 Lingcod: PPA Analysis.....	22

3.3.4	Black Rockfish PPA Analysis	23
3.3.5	Copper rockfish: PPA Analysis.....	25
3.3.6	Quillback rockfish: PPA Analysis	28
3.3.7	Squarespot rockfish: PPA Analysis	31
3.3.8	Vermilion and vermilion/sunset rockfish.....	33
3.4	Summary Table.....	35
4.	Considerations Relating to Council Operating Procedures (COPs).....	39
4.1	New Information and Timing Considerations.....	39
	Proposal 1	39
	Proposal 2	39
	Comparison of Proposals.....	40
5.	Magnuson-Stevens Act National Standards	43
5.1	National Standard 1 - Optimum Yield	43
5.2	National Standard 2 - Best Scientific Information Available.....	44
5.3	National Standard 3: Management Units	45
5.4	National Standard 4: Allocations.....	45
5.5	National Standard 5: Efficiency.....	46
5.6	National Standard 6: Variations and Contingencies	46
5.7	National Standard 7: Costs and Benefits.....	46
5.8	National Standard 8: Communities.....	47
5.9	National Standard 9: Bycatch.....	47
5.10	National Standard 10: Safety of Life at Sea.....	47
5.11	Consistency of the Proposed Action with Other Applicable MSA Provisions	47
	5.11.1 MSA Section 303.....	47
	5.11.2 MSA Section 600.305.....	48
6.	Glossary	49
7.	Literature Cited	51
8.	Contributors	69
	Appendix A: Biological Information	A1
	Appendix A Synthesis.....	A1
	Synthesis of Spatial Population Structure Literature	A3
	Priority Species Literature Review	A6
	Black rockfish	A6
	Canary rockfish.....	A7

Copper rockfish.....	A9
Dover Sole	A10
Lingcod	A10
Pacific spiny dogfish	A11
Petrале Sole	A12
Quillback rockfish.....	A12
Rex Sole.....	A13
Sablefish	A14
Shortspine thornyhead.....	A14
Squarespot rockfish	A15
Vermilion and Vermilion/Sunset rockfish.....	A16
Appendix B - Differential Harvest Control Rules	B1
Sub-Alternative 1a: Single Stock, Multiple Assessment Areas, Multiple HCRs, Complexes .	B2
Sub-Alternative 1b: 2- Single Stock, Multiple Assessment Areas, Single HCR, Complexes .	B3
Sub-Alternative 1a/b Analysis	B4
Appendix C - Species with only one Alternative Considered.....	C1
Canary rockfish, Dover sole, Pacific spiny dogfish, petrale sole, rex sole, sablefish, and shortspine thornyhead.....	C1
Lingcod.....	C3

List of Tables

Table 1. Priority groundfish species for Amendment 31, and their most recent assessment year. .	3
Table 2. Action alternatives to be analyzed for priority groundfish species. Numbering of Alternatives reflects the number of area delineations considered for the priority species. PPA=Preliminary preferred alternative.....	9
Table 3. Alternatives and corresponding stock area delineations for black, copper, quillback, squarespot, vermilion and vermilion/sunset rockfishes. PPA=Preliminary preferred alternative.	17
Table 4. Comparison of the Council recommended Preliminary Preferred Alternative (PPA) to the annual catch limit (ACL) scale of species, NMFS status area, scientific and statistical committee (SSC) recommendation for population structure, and the most recent assessment, for species with only a single alternative (Alternative 1) considered (see Section 1.5).....	21
Table 5. Comparison of the Council recommended Preliminary Preferred Alternative (PPA) to the annual catch limit (ACL) scale of species, NMFS status area, scientific and statistical committee (SSC) recommendation for population (Pop) structure recommendation , and the most recent assessment for lingcod. North = N, South = S.....	22
Table 6. Comparison of the Council recommended Preliminary Preferred Alternative (PPA) to the annual catch limit (ACL) scale of species, NMFS status area, scientific and statistical committee	

(SSC) recommendation for population (Pop) structure recommendation, and the most recent assessment for black rockfish.23

Table 7: Comparison of the Council recommended Preliminary Preferred Alternative (PPA) to the annual catch limit (ACL) scale of species, NMFS status area, scientific and statistical committee (SSC) recommendation for population (Pop) structure recommendation, and the most recent assessment, for copper rockfish. North = “N.” and South = “S.”25

Table 8. Comparison of the Council recommended Preliminary Preferred Alternative (PPA) to the annual catch limit (ACL) scale of species, NMFS status area, scientific and statistical committee (SSC) recommendation for population (Pop) structure recommendation, and the most recent assessment, for quillback rockfish.29

Table 9. Comparison of the Council recommended Preliminary Preferred Alternative (PPA) to the annual catch limit (ACL) scale of species, NMFS status area, scientific and statistical committee (SSC) recommendation for population (Pop) structure recommendation, and the most recent assessment for squarespot rockfish. North = N and South = S.....32

Table 10. Comparison of annual catch limit (ACL) scale of species, NMFS status area, scientific and statistical committee (SSC) recommendation for) for population structure, and the most recent assessment for vermilion/sunset rockfish. North =N and South = S34

Table 11. Table showing the combined information by species for this action. The left side shows the species, the alternatives it is considered under, and the resulting geographic delineation of the alternative. The right side summarizes the scientific and statistical committee (SSC) recommendation for population structure geographical delineation(s), NMFS Status Area, geographic scale at which the ACL is currently set, and the most recent assessment geographic delineation(s) and year. Preliminary Preferred Alternative (PPA) is noted in bold as is alternatives added to the Range of Alternatives36

Table of Figures

Figure 1. Diagram from National Marine Fisheries Service simplifying the process of determining if a stock is in need of conservation and management. Source NMFS NS1 Guidelines.2

Figure 2. Illustration of harvest specifications calculation methods (i.e., harvest control rules) for copper rockfish (also applicable to vermilion and vermilion/sunset rockfishes) under Alternative 2a – PPA with four assessment units and when managed in a rockfish stock complex. The hashed bracket represents the stock for which overfished status would be determined under Alternative 2a, the diamond represents σ/P^* , triangle represents the ACL control rule, and arrows represent apportionments. Circles indicate values that are specified in regulations (for informational purposes).....27

Figure 3. Illustration of harvest specifications calculation methods (i.e., harvest control rules) for copper, vermilion, and vermilion/sunset rockfishes under Alternative 3 or 3a with four assessment units and managed in a rockfish stock complex. The hashed bracket represents the stock for which overfished status would be determined under Alternative 3, the diamond represents σ/P^* , triangle represents the ACL control rule, and arrows represent apportionments. Circles indicate values that are specified in regulations (for informational purposes).....28

Figure 4. Biennial groundfish management cycle diagram showing two proposals (Proposal 1 in purple and Proposal 2 in green) for potential on-ramps for new scientific information to inform stock definitions.41

Executive Summary

ES 1 Introduction

This document analyzes the anticipated tradeoffs of alternative stock definitions for priority groundfish species as adopted in the preliminary preferred alternative (PPA) by the Council. Priority species are identified as those with assessments completed in 2021 and those scheduled to be assessed in 2023 and are as follows: black rockfish, canary rockfish, copper rockfish, Dover sole, lingcod, Pacific spiny dogfish, petrale sole, quillback rockfish, rex sole, shortspine thornyhead, squarespot rockfish, vermilion rockfish, and vermilion/sunset rockfish.

ES 1.1 Purpose and Need

The [Pacific Coast Groundfish Fishery Management Plan](#) (FMP) does not explicitly define groundfish stocks.¹ The Pacific Fishery Management Council (Council) adopted the following purpose and need statement for this action at their September 2022 meeting.

“With Amendment 31 to the Pacific Fishery Management Council’s (Council) Groundfish FMP, the Council intends to enhance the ability to attain sustainability objectives, especially those outlined in National Standard (NS) 1² of the Magnuson Stevens Act as guided by NS 3³ and informed by NS 2⁴. Appropriate specification of stocks in need of conservation and management at a geographic and stock complex level for assessing overfished status and determining if overfishing is occurring is a foundational aspect of sustainability, and instrumental in the Council’s ability to attain Optimum Yield objectives. With this Amendment, the Council intends to identify a subset of species within the Groundfish FMP to define stock boundaries for status determination based on key biological, ecological, social, and economic information currently available. It is the Council’s intent that, when this Amendment is completed, NMFS will make the necessary status determinations concerning the identified groundfish stocks managed under the Groundfish FMP.”

Agenda Item G.5 Motion, in writing, September 2022

ES 1.2 Proposed Action

In accordance with the [Magnuson-Stevens Fishery Conservation and Management Act](#) (MSA) – the principal legal basis for fishery management within the Exclusive Economic Zone (EEZ) and the [National Standard Guidelines](#) (§ 600.305) –the proposed action is to identify and define stocks for 14 identified priority groundfish species (Table ES 1). The action will require both an FMP amendment (Amendment 31). This action makes no changes to the species composition of 2023-2024 groundfish stock complexes. This action is not intended to revise the harvest specifications

¹ The term "stock of fish" means a species, subspecies, geographical grouping, or other category of fish capable of management as a unit (16 USC. 1802 MSA § 3(42)).

² NS 1 - Conservation and management measures shall prevent overfishing while achieving, on a continuing basis, the optimum yield from each fishery for the United States fishing industry.

³NS 3 - To the extent practicable, an individual stock of fish shall be managed as a unit throughout its range, and interrelated stocks of fish shall be managed as a unit or in close coordination.

⁴ NS 2 - Conservation and management measures shall be based upon the best scientific information available (BSIA).

framework in the FMP or have allocative effects. Harvest specifications and management measures for any newly defined stocks would be developed and implemented as part of the 2025-2026 groundfish biennial specifications and management measures process, consistent with Section X of the Groundfish FMP.

Table ES 1. Priority groundfish species for this action under Amendment 31 and the year of the most recent assessment.

Assessment Year	
2021	2023
Dover sole	Black rockfish
Lingcod	Canary rockfish
Quillback rockfish	Copper rockfish a/
Pacific spiny dogfish	Petrable sole
Squarespot rockfish	Rex sole
Vermilion rockfish c/	Sablefish b/
Vermilion/Sunset rockfish c/	Shortspine thornyhead

a/ Copper rockfish was assessed by a data moderate assessment in 2021. In 2023, a full assessment(s) is planned for California only.

b/Sablefish will have a limited update assessment in 2023. This update assessment will update estimates of depletion, and could necessitate a change in overfished/not overfished stock status. It will update OFL estimates (metric tons) for 2025 and beyond, which would be the basis of future overfishing determinations.

c/ Vermilion rockfish was assessed off of Oregon and Washington. Vermilion/sunset rockfish are a cryptic species pair and were assessed as a complex -as the species cannot be easily separated in the data or in the field – off of California only. Sunset rockfish do not appear to range into Oregon or Washington.

ES 1.3 Analytical Process

First, a literature review was conducted, as synthesized and presented in Appendix A: Biological Information.

This analysis is an expansion of the methods used in [Agenda Item H.5, Attachment 1, November 2022](#) which were to examine the genetics, adult movement, and larval dispersal of the priority species as factors for accurately identifying population structure along the coast.

In the Comparison of the Alternatives (Chapter 3) a series of tables are presented that illustrate the geographic area stratification among a variety of population structure factors for each species considered in this action. Multiple factors of population structure were investigated (e.g., genetics, larval dispersal, etc.) as well as perspectives garnered from SSC recommendations of best scientific information available (BSIA); the geographic scale of assessments, historic NMFS stock status determinations areas; and the geographic scale of annual catch limits (ACL) for the species or stock complex in which the species is managed (See Section 1.5).

A quantitative analysis for this action is not possible; therefore, the analytical process of this document follows a qualitative approach. A quantitative comparison could encourage outcome-based decision making on stock definitions. The qualitative comparison of the alternatives in Chapter 3 Comparison of the Alternatives weighs the tradeoffs between three types of metrics; biological risks to the species, socioeconomic risks to communities, and management burden.

We evaluate these risks by applying the harvest specifications framework in the FMP to the proposed stock units to make assumptions about the possible impacts that may flow from Amendment 31. However, this is just for analytical purposes as Amendment 31 itself is administrative in nature and any impacts will occur when harvest control rules are applied to the stocks in the 2025-2026 harvest specifications process.

The risks described in this document assume that the harvest control framework would be applied to these stocks, but because the next harvest specifications cycle has not yet started and therefore the actual impacts are speculative, the discussion of risks and burden are qualitative. Biological risks may be in the form of localized depletion or the fishery not achieving optimum yield (OY). Socioeconomic risk may be in the form of a lack of fairness and equity of the allocation of harvest privileges or rebuilding restrictions/benefits. Management burden may change in management compared to status quo, as characterized by the 2023-24 harvest specifications and management measures (PFMC, 2022a). Further exploration of trade-offs socioeconomic risk and management burden are highly speculative and are not the subject of further discussion at this time. The analytical steps are described in Section 1.5.

Appendix A: Biological Information compiles information regarding population dynamics and biological information for the priority species. Appendix A: Biological Information is incorporated by reference throughout this analysis.

ES 1.4 Alternatives

The Council adopted the Range of Alternatives (ROA) for this action at its November 2022 meeting. The analysis of the ROA was presented to the Council at the March 2023 meeting in [Agenda Item F.7, Attachment 1](#). The alternative numbering reflects the number of geographic areas considered, e.g., Alternative 1 is for those priority species considered under one stock delineation area (i.e., single stock); Alternative 2 is for priority species considered under two stock delineation areas (e.g., two stocks north of and south of 40° 10' N. latitude), etc. The Council also added additional alternatives within the ROA at its March 2023 meeting. One alternative will ultimately be adopted for each species, i.e., multiple alternatives cannot be selected for a single species. Each alternative would amend the FMP to define a priority species or cryptic species pair (i.e., vermilion/sunset rockfish) as either one stock, two stocks, three stocks, or four stocks.

- **No Action** would not define priority species as stocks in the FMP.
- **Alternative 1** a single stock, single area within the Fishery Management Unit (FMU).
 - **Sub-Alternative 1a**⁵ considers a single stock with multiple harvest control rules applied to sub-area assessments.
- **Alternative 2** two stocks within the FMU, separated north of and south of 40° 10' N. lat.
 - **Sub-Alternative 2a** two stocks within the FMU, separated north and south of 42° N. lat.; i.e., a Washington and Oregon stock, and a California stock.
- **Alternative 3** three stocks within the FMU, aligned with state boundaries (i.e., a California stock, an Oregon stock, and a Washington stock).

⁵ Sub-Alternative 1a (varying harvest control rules [HCRs] by sub-area assessment) and Sub-Alternative 1b (single HCR per stock) were not selected as PPA and therefore are described in detail in Appendix 2. In this document, Sub-Alternative 1b is subsumed into Alternative 1, as described in Section 2.3.

- **Sub-Alternative 3a** three stocks; a Washington and Oregon stock (north of 42° N. lat.), a northern California stock (between 42° N. lat. and 34° 27' N. lat.), and a southern California stock (south of 34° 27' N. lat.).
- **Alternative 4** four stocks; a Washington stock, an Oregon stock, a northern California stock (north of 34° 27' N. lat.), and a southern California stock (south of 34° 27' N. lat.).

ES 1.5 Preliminary Preferred Alternative and Range of Alternatives Modifications

The Council adopted a Preliminary Preferred Alternative (PPA) and added alternatives to the ROA at its March 2023 meeting. Table ES 2 shows the PPA for each species in a column labeled Alternative (s). The new alternatives are denoted as “new” in the same column. For all the action alternatives, some additional caveats and considerations apply, which are detailed in Section 2.1.2.

Table ES 2. Action alternatives (Alt) to be analyzed for priority groundfish species. Numbering of Alternatives reflects the number of area delineations considered for the species. Single stock means one stock within the fishery management unit, which could or could not be delineated as coastwide. PPA=Preliminary preferred alternative. North =N. South = S.

Priority Species	Alternative(s)	Number of Stocks	Area(s) Delineation
Species considered under a single Alternative			
Canary rockfish	1 (PPA)	Single Stock	Single area
Dover sole	1 (PPA)	Single Stock	Single area
Pacific spiny dogfish	1 (PPA)	Single Stock	Single area
Petrale sole	1 (PPA)	Single Stock	Single area
Rex sole	1 (PPA)	Single Stock	Single area
Sablefish	1 (PPA)	Single Stock	Single area
Shortspine thornyhead	1 (PPA)	Single Stock	Single area
Lingcod	2 (PPA)	Two Stocks	a N. of 40° 10' N. lat. stock and S. 40° 10' N. lat. stock
Species considered under a multiple Alternatives			
Black rockfish	1	Single Stock	Single area
	3 (PPA)	Three Stocks	a Washington stock, an Oregon stock, and a California stock
Quillback Rockfish a/	1	Single Stock	Single area
	2a new	Two Stocks	a N. of 42° N. lat. stock and a S. 42° N. lat. stock
	3 (PPA)	Three Stocks	a Washington stock, an Oregon stock, and a California stock
Squarespot Rockfish	1 (PPA)	Single Stock	Single area
	3	Three Stocks	a Washington stock, an Oregon stock, and a California stock
Copper Rockfish a/	1	Single Stock	Single area
	2a (PPA)	Two Stocks	a N. of 42° N. lat. stock and a S. 42° N. lat. stock
	3	Three Stocks	a Washington stock, an Oregon stock, and a California stock
Vermilion Rockfish and Vermilion/Sunset Rockfish a/ b/ c/	1	Single Stock	Single area
	2	Two Stocks	a N. of 40° 10' N. lat. stock and a S. 40° 10' N. lat. stock
	2a new	Two Stocks	a N. of 42° N. lat. vermilion rockfish stock and a S. 42° N. lat. vermilion/sunset rockfish stock

Priority Species	Alternative(s)	Number of Stocks	Area(s) Delineation
Vermilion Rockfish and Vermilion/Sunset Rockfish continued a/ b/ c/	3	Three Stocks	Washington vermilion rockfish stock, Oregon vermilion rockfish stock, & California vermilion/sunset rockfish stock
	3a	Three stocks	a Washington and an Oregon [N. of 42° N. lat.] stock, a Northern California [north of 34° 27' N. lat.] stock, and a Southern California [south of 34° 27' N. lat.] stock
	4	Four Stocks	a Washington stock, an Oregon stock, a Northern California [north of 34° 27' N. lat.] stock, and a Southern California [south of 34° 27' N. lat.] stock

a/ Note: New Sub-Alternative 2a for quillback rockfish added by Council in March 2023. Sub-Alternative 2a for copper rockfish per SSC status recommendation ([Agenda Item E.3.a, Supplemental SSC Report 1, November 2021](#)); New Sub-Alternative 2a for vermilion and vermilion/sunset rockfish added by the Council in March 2023.

b/ If Alt. 2 is selected, a new assessment for vermilion/sunset rockfish would need to be performed to determine the overfished status at this geographic scale.

c/ Note: New Sub-Alternative 3a for vermilion rockfish and vermilion/sunset rockfish per SSC recommendation ([Agenda Item E.3.a, Supplemental SSC Report 1, November 2021](#)).

ES 1.6 Comparison of Alternatives

Table ES 3 presents a summarized comparison of the combined information for each species considered in this action.

Chapter 3, Comparison of the Alternatives, compares and contrasts tradeoffs of the alternatives after the harvest specifications framework is applied to each alternative stock. For species with only one action Alternative, rationale in support of that single alternative and explanation of why additional alternatives are not warranted is also offered (Appendix C - Species with only one Alternative Considered).

The bulk of the comparative analysis is species-specific (Chapter 3) and focuses on the following three metrics: biological risks to the species, socioeconomic risks to communities, and management burden for the Council as described above. These metrics are described qualitatively as the actual impacts from applying the harvest control rule framework to the new stocks will occur in the 2025-2026 harvest specifications process and at this time those impacts are unknown. Amendment 31 is administrative in nature and will amend the FMP to define priority species as stocks. However, the discussion of these three metrics is intended to aid the decision-making process by making assumptions about what impacts may flow if the harvest control rule framework is applied to the proposed stocks.

Biological

Biological risks may be in the form of localized depletion or the fishery not achieving OY. Localized depletion can lead to range contraction or fragmentation.⁶ The analysis indicated Canary rockfish, Dover sole, Pacific spiny dogfish, petrale sole, rex sole, sablefish, squarespot rockfish, and shortspine thornyhead have no discernible population structure. Generally, this means an

⁶ See Section 3.5.3 of [NOAA Technical Memorandum NMFS-F/SPO-31, July 1998](#)

Alternative 1 stock definition for these species is unlikely to increase risk of localized depletion or not achieving OY compared to status quo management. Black, copper, quillback, vermilion and vermilion/sunset rockfishes and lingcod have distinct population structure. Alternatives 2-4 for these rockfishes and lingcod may decrease the risk of localized depletion and maintain or increase the Council's ability to achieve OY for these stocks.

Socioeconomic

Socioeconomic risk may be in the form of a lack of fairness and equity of the allocation of harvest privileges or rebuilding restrictions/benefits. This is not a concern for species with only one alternative considered or squarespot rockfish. Squarespot rockfish occurs predominantly off of California, south of 40°10' N. lat. Any allocation or rebuilding restrictions/benefits are likely to remain the same regardless if Alternative 1 or Alternative 3 were adopted. Generally, Alternative 3 (state-specific) stock definitions for black, copper, quillback, vermilion, and vermilion/sunset rockfishes were the least likely to trigger future allocative actions by the Council and had the highest likelihood that rebuilding burden and recovery benefits would be fair and equitable. This is because the status-quo management in the harvest specifications process includes state-specific harvest targets/shares.

Management

Management burden may come in the form of allocative management recommendations the Council may need to make after Amendment 31 is adopted. Generally, Alternative 3 is least likely to require additional allocative decisions to achieve status quo management (e.g., state-specific harvest targets/shares) for black, copper, quillback, vermilion, and vermilion/sunset rockfishes.

ES 1.7 Magnuson-Stevens Act

Chapter 5 presents considerations regarding National Standards for consideration before the Final Preferred Alternative(s) is adopted.

Table ES 3. Table showing the combined information by species for this action. The Preliminary Preferred Alternative (PPA) is identified. The left side shows the species, the alternative(s) it is considered under, and the resulting geographic delineation of the alternative. The right side summarizes the scientific and statistical committee (SSC) recommendation for population structure geographical delineation(s), NMFS Status Area, geographic scale at which the ACL is currently set, and the most recent assessment geographic delineation(s) and year. North = N, South = S, Washington = WA, Oregon = OR, & California = CA

Alternative Specifics by Species			Pop. Structure, Status, ACL scale, and Assessment Delineations Information			
Species	Alternative	Delineation	SSC population structure	NMFS Status Area	ACL Scale	Assessment Stratification and Year b/
Canary Rockfish	1 (PPA)	Single area	Coastwide	Pacific Coast	Coastwide	Coastwide (2015)
Dover Sole	1 (PPA)	Single area	Coastwide	Pacific Coast	Coastwide	Coastwide (2021)
Pacific Spiny Dogfish	1 (PPA)	Single area	Coastwide	Pacific Coast	Coastwide	Coastwide (2021)
Petrale Sole	1 (PPA)	Single area	Coastwide	Pacific Coast	Coastwide	Coastwide (2019)
Rex Sole	1 (PPA)	Single area	Coastwide	Pacific Coast	Coastwide	Coastwide (2013)
Shortspine Thornyhead	1 (PPA)	Single area	Coastwide	Pacific Coast	Coastwide h/	Coastwide (2013)
Sablefish	1 (PPA)	Single area	Coastwide	Pacific Coast	Coastwide g/	Coastwide (2019)
Lingcod	2 (PPA)	N. of 40° 10' N. lat.	N. of 40° 10' N. lat.	N. Pacific Coast	N. of 40° 10' N. lat.	N. of 40° 10' N. lat. (2021)
		S. of 40° 10' N. lat.	S. of 40° 10' N. lat.	S. Pacific Coast	S. of 40° 10' N. lat.	S. of 40° 10' N. lat. (2021)
Black Rockfish c/	1	Single area	Washington Oregon California	Washington Oregon California	Washington Oregon California	Washington (2015) Oregon (2015) California (2015)
	3 (PPA)	Washington				
		Oregon				
		California				
Copper Rockfish	1	Single area	WA/OR (North of 42° N. lat.) CA (South of 42° N. lat.)	Pacific Coast d/	Nearshore Rockfish Complex N. of 40° 10' N. lat.	Washington (2021) Oregon (2021) California N of 34° 27' N. lat. (2021)
	2a (PPA)	N of 42° N. lat				
		S of 42° N. lat				
	3	Washington			Nearshore Rockfish Complex S. of 40° 10' N. lat.	California S of 34° 27' N. lat. (2021)
		Oregon				
		California				

Alternative Specifics by Species			Pop. Structure, Status, ACL scale, and Assessment Delineations Information			
Species	Alternative	Delineation	SSC population structure	NMFS Status Area	ACL Scale	Assessment Stratification and Year b/
Quillback Rockfish	1	Single area	Washington Oregon California	a/	Nearshore Rockfish Complex N. of 40° 10' N. lat.	Washington (2021) Oregon (2021) California (2021)
	2a new	N of 42° N. lat				
		S of 42° N. lat				
	3 (PPA)	Washington				
		Oregon				
		California				
Squarespot Rockfish	1 (PPA)	Single area	California	a/	Shelf Rockfish Complex N. of 40° 10' N. lat.	California (2021)
	3	Washington				
		Oregon				
		California				
Vermilion and Vermilion/ Sunset Rockfish	1	Single area	Washington and Oregon h/ California –N of 34° 27' N. lat. California S of 34° 27' N. lat.	a/	Shelf Rockfish Complex N. of 40° 10' N. lat.	Washington (2021) Oregon (2021) California N of 34° 27' N. lat. (2021) California S of 34° 27' N. lat. (2021)
	2	N. of 40° 10' N. lat.				
		S. of 40° 10' N. lat.				
	2a new	N of 42° N. lat <i>Vermilion rockfish stock</i>				
		S of 42° N. lat <i>Vermilion/Sunset rockfish stock</i>				
	3	Washington <i>Vermilion rockfish stock</i>				

Alternative Specifics by Species			Pop. Structure, Status, ACL scale, and Assessment Delineations Information			
Species	Alternative	Delineation	SSC population structure	NMFS Status Area	ACL Scale	Assessment Stratification and Year b/
Vermilion and Vermilion/ Sunset Rockfish <i>continued</i>		Oregon <i>Vermilion rockfish stock</i>				
		California <i>Vermilion/Sunset rockfish stock</i>				
	3a	WA & OR				
		N of 34° 27' N. lat <i>Vermilion/Sunset rockfish stock</i>				
		S of 34° 27' N. lat <i>Vermilion/Sunset rockfish stock</i>				
	4	WA <i>Vermilion rockfish stock</i>				
		OR <i>Vermilion rockfish stock</i>				
		N of 34° 27' N. lat <i>Vermilion/Sunset rockfish stock</i>				
		S of 34° 27' N. lat <i>Vermilion/Sunset rockfish stock</i>				

a/ Species have overfished or overfishing status as “unknown”, as of [June 2022 \(NMFS 2022\)](#).

b/ Most recent sub-area for assessments endorsed as BSIA by the SSC and NMFS. Assessment area stratifications may change in future assessments.

c/ Black rockfish off Washington and California each have both overfished and overfishing status determinations. Oregon Black rockfish is managed in a complex and only has overfished status determinations. Overfishing status determinations are made for the Oregon black/blue/deacon Rockfish Complex.

- d/ Note: NMFS made a “not overfished” status determination for “copper rockfish - Pacific Coast” based on the 2013 assessment, though catches since that time have doubled. The 2013 assessment also assumed a more optimistic status in 2000 than was found in the 2021 stock assessment.
- f/ Shortspine thornyhead has an ACL that is apportioned north and south of 34° 27' N. lat., consistent with allocations in the FMP.
- g/ Sablefish has an ACL that is apportioned north and south of 36° N. lat., consistent with allocations in the FMP.
- h/ The SSC recommended combining vermilion rockfish in Oregon and Washington for status determination due to lack of vermilion rockfish population structure between the two areas ([Agenda Item E.3.a, SSC Report 1, November 2021](#)).
- i/ Quillback rockfish was assessed as a three state model in 2022. The assessments results were pooled to derive a coastwide OFL/ABC/ACL, which was then apportioned into the nearshore rockfish complexes per standard procedure detailed in the FMP and SAFE (PFMC, 2022a and 2022b)

1. Introduction

The Council is required to identify stocks in need of conservation and management per the Magnuson-Stevens Fishery Conservation and Management Act (MSA) and its National Standards. A non-exhaustive list of factors that can be used to determine/define stocks is well described at [§600.305\(c\)\(1\)](#). FMPs must describe status determination criteria, or the measurable and objective factors (e.g., OFL, MSST, etc.), for each managed stock to determine if a stock is overfished or whether overfishing is occurring ([§600.310\(e\)\(2\)\(i\)\(A\)](#)). NMFS makes stock status determinations based on the condition of a stock relative to the status determination criteria.

Stock status determination is a NMFS decision whether a stock of fish is in an overfished condition, approaching an overfished condition, and/or is subject to overfishing. NMFS makes these determinations based on BSIA and the status determination criteria described in the PCGFMP and reports them to Congress quarterly.

The FMP currently lists the species managed under the FMP (see [Chapter 3, Table 3-1](#)) but does not define and delineate groundfish stocks in the fishery management unit (FMU).

Under the harvest specifications framework in the FMP, the OFL directly corresponds to the geographic extent of the stock⁷. ACLs are generally calculated for the same geographical extent as the OFL, though they can be apportioned to regions (e.g., sablefish regional ACLs), which is generally done consistent with the allocation framework in the FMP.

As noted in [MSA §303\(a\)\(1\)](#) "...fishery management plan... shall...contain the conservation and management measures... necessary and appropriate... to prevent overfishing and rebuild overfished stocks...". In order to meet this, NS1 guidelines at [§600.310\(d\)](#) direct "...Councils should identify in their FMPs the stocks that require conservation and management. Such stocks must have ACLs, other reference points, and accountability measures...". As shown in the following infographic (Figure 1), NS1 identifies criteria to assist the Council in determining if a species (called a 'stock' in the figure) is in need of conservation and management. This analysis presumes that the priority species considered in this action are in need of conservation and management, and doing otherwise is outside the scope of Amendment 31. In order to create a common literary 'currency', a Glossary was created for this analytical document.

⁷ because it is the annual amount of catch corresponding to the estimate of the maximum fishing mortality threshold (MFMT) applied to the stock's abundance ([600.310\(e\)\(2\)\(i\)\(D\)](#))

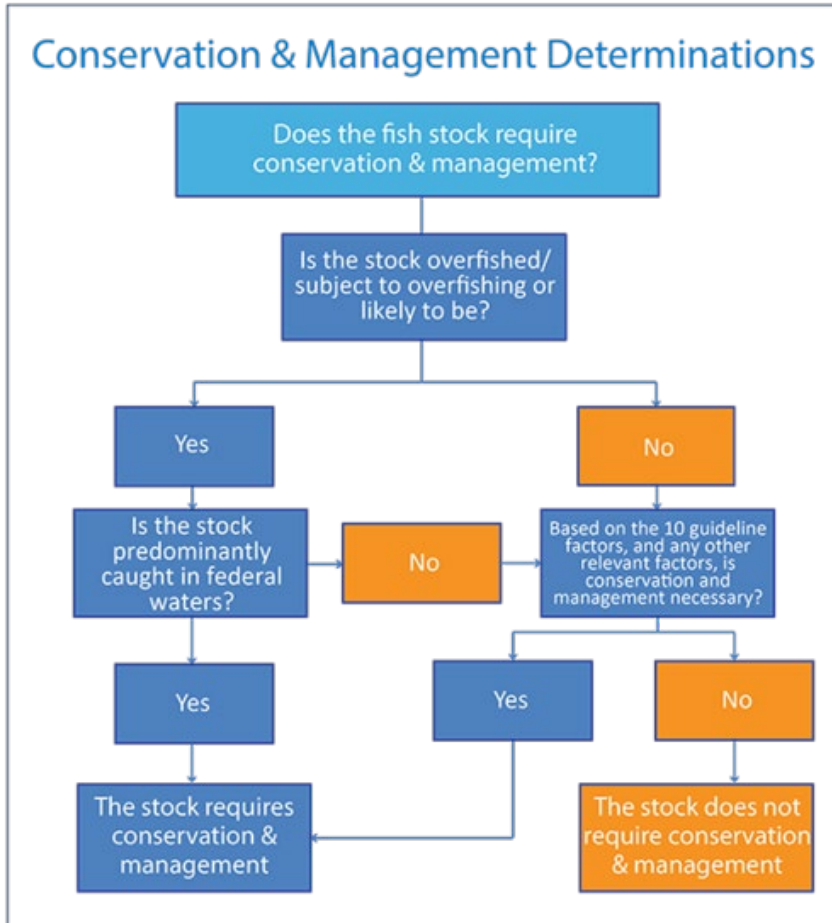

Figure 1. Diagram from National Marine Fisheries Service simplifying the process of determining if a stock is in need of conservation and management. Source NMFS NS1 Guidelines.

1.1 Proposed Action

As described above in the Introduction, the proposed action would amend the FMP to identify and define stocks for each of the Council identified priority⁸ groundfish species (Table 1) so that NMFS can make status determinations at the end of 2023 for a 2024 report to Congress on the status of stocks. This action makes no changes to the species composition of the 2023-2024 harvest specifications and management measures and therefore those measures will remain unchanged. This action is not intended to have allocative effects. Harvest specifications and management measures for any newly defined stocks would be developed and implemented as part of the 2025-2026 groundfish biennial specifications and management measures process, consistent with Section 5.1 of the Groundfish FMP, which the Council is beginning to work on in June 2023.

⁸ Priority species were identified to have stocks defined in Phase 1 because they were assessed in 2021 or scheduled to be assessed in 2023, prior to the start of the 2025-26 biennial specifications and management measures cycle. Other species, including stock complex considerations, will be taken up in a future Phase 2 action.

Table 1. Priority groundfish species for Amendment 31, and their most recent assessment year.

Assessment Year	
2021	2023
Dover sole	Black rockfish
Lingcod	Canary rockfish
Quillback rockfish	Copper rockfish ^{a/}
Pacific spiny dogfish	Petrals sole
Squarespot rockfish	Rex sole
Vermilion rockfish ^{c/}	Sablefish (update) ^{b/}
Vermilion/Sunset rockfish ^{c/}	Shortspine thornyhead

a/ Copper rockfish was assessed in Washington, Oregon, northern California (north of 34° 27' N. lat.) and southern California (south of 34° 27' N. lat.) by a data moderate assessment in 2021. In 2023, a full assessment(s) is planned for California only.

b/Sablefish will have a limited update assessment in 2023. This update assessment will update estimates of depletion, and could necessitate a change in overfished/not overfished stock status. It will update OFL estimates (metric tons) for 2025 and beyond, which would be the basis of future overfishing determinations.

c/ Vermilion rockfish was assessed off of Oregon and Washington. Vermilion/sunset rockfish are a cryptic species pair and were assessed as a complex -as the species cannot be easily separated in the data or in the field – off of California only. Sunset rockfish do not appear to range into Oregon or Washington.

1.2 Description of Management Area

The management area is the West Coast Exclusive Economic Zone (EEZ) —defined as the area from 3 nautical miles to 200 nautical miles seaward of Washington, Oregon, and California state waters and the communities that engage in fishing in waters off these states. While some of the species included in this action co-occur in the EEZ and state waters (0-3 nm), this action would only amend the FMP to include the stock definitions for purposes of management in federal waters. The states would separately need to take conforming action to change stock and species management for state fisheries to reflect the boundaries considered in this action. This geographic area within the jurisdiction of the FMP may be referred to as the fishery management unit (FMU) and is depicted in [Figure 3-1](#) of the FMP (PFMC, 2022a).

1.3 Purpose and Need

The Council adopted the following purpose and need statement for this action at their September 2022 meeting.

“With Amendment 31 to the Pacific Fishery Management Council’s (Council) Groundfish FMP, the Council intends to enhance the ability to attain sustainability objectives, especially those outlined in National Standard 1 of the Magnuson Stevens Act as guided by National Standard 3 and informed by National Standard 2. Appropriate specification of stocks in need of conservation and management at a geographic and stock complex level for assessing overfished status and determining if overfishing is occurring is a foundational aspect of sustainability, and instrumental in the Council’s ability to attain Optimum Yield objectives. With this Amendment, the Council intends to identify a subset of species within the Groundfish FMP to define stock boundaries for status determination based on key biological, ecological, social, and economic information currently available. It is the Council’s intent

that, when this Amendment is completed, NMFS will make the necessary status determinations concerning the identified groundfish stocks managed under the Groundfish FMP.”
G.5 Motion, in writing, September 2022

1.4 History of this Action

The history of this action is detailed in the hyperlinked reports. These reports are incorporated by reference, though information is summarized, as appropriate, throughout the following analysis.

In March 2022, NMFS outlined concerns regarding the FMP in their report to the Council ([Agenda Item E.3.a, NMFS Report 1, March 2022](#)) and that NMFS was unable to report status to Congress as required.⁹ NMFS recommended the Council “...initiate action to ensure that stocks that are managed at a scale other than coastwide for the purposes of status determination, and other stocks, are clearly identified in the FMP” ([Agenda Item E.3.a, NMFS Report 1, March 2022](#)).

The Council initiated scoping in June 2022 for Amendment 31 to define stocks in the FMP (see [Agenda Item F.4, Attachment 1, June 2022](#)). The Council requested initial analyses to support the Amendment, which was provided in September 2022 ([Agenda Item G.5, Attachment 1 and Attachment 2, September 2022](#)). In September 2022, the Council adopted the Purpose and Need statement for Amendment 31 (Section 1.3).

The term **stock** is defined in the MSA as “a species, subspecies, geographical grouping, or other category of fish capable of management as a unit.” – 16 U.S.C. 1802 MSA §3(42)

At its September 2022 meeting, the Council identified the priority species (Table 1) to be covered under Amendment 31. Council staff developed a white paper, per Council instructions, and provided a draft range of alternatives (ROA) for Council review ([Agenda Item H.5, Attachment 1, November 2022](#) [hereinafter “Attachment 1, Nov. 2022”]). The Council adopted an ROA at its November 2022 meeting (see Chapter 2: Description of Alternatives), for further analysis. Over winter, the Alternatives were re-numbered from what was presented in [Attachment 1, November 2022](#), into the numbering presented in [Agenda Item F.7, Attachment 1, March 2023 and this document](#).

At its March 2023 meeting, the Council identified a PPA for 12 out of 14 species. The Council did not identify a PPA for vermilion and vermilion/sunset rockfishes. The Council added a Sub-Alternative 2a for vermilion, vermilion/sunset, and quillback rockfishes.

1.5 Analytical Process

In defining stocks, the Council must use BSIA, but also take into account the MSA and the National Standards, the goals, objectives and existing frameworks in the FMP, and socioeconomics of the fishery.

The focus of Amendment 31 is to define the unit stock, including spatial delineations, for the priority species (Table 1). Current scientific literature and the advice of the Science and Statistical Committee (SSC) suggests population structure is a foundation to defining a species as a stock and

⁹ MSA §[304\(c\)\(1\)](#)

can help to delineate the stock(s) on a geographic scale (see [Agenda Item H.5.a, Supplemental SSC Report 1, November 2022](#) and [Agenda Item E.3.a, Supplemental SSC Report 1, November 2021](#)). A literature review was conducted, as synthesized and presented in full in Appendix A: Biological Information. Defining stocks, particularly if those stocks are delineated at a similar geographic scale as the current harvest specifications or management measures, does not change fishing effort, harvest levels, or timing and location of fishing and landings. To better gauge the trade-offs of alternative stock definitions, a presumption is made that the harvest specifications framework in the FMP is applied to the stock defined under each alternative. It is the application of that framework to the stock (a future biennial harvest specifications action) that may have differential biological impacts to managed fish species. For these reasons, a quantitative analysis for this action is not possible, therefore the analysis of the alternatives follows a qualitative approach.

Analysts provide a comparison of current management and population assessment geographic area stratifications for the priority species for the Council as a baseline of sorts to compare and contrast the stock definition Alternatives when the harvest specifications framework is applied to the alternative stocks. In the Comparison of the Alternatives (Chapter 3), a series of tables are presented that illustrates geographic area stratification in relation to population structure metrics for each species considered in this action. While on an individual basis, these factors may not definitively identify a population or sub-population, yet when combined they can indicate population structure. Multiple factors of population structure were investigated (e.g., genetics, larval dispersal, etc.) as well as perspectives garnered from SSC recommendations of best scientific information available (BSIA); the geographic scale of assessments, historic NMFS stock status determinations areas; and the geographic scale of annual catch limits (ACL) for the species or stock complex in which the species is managed. The factors considered in analyzing each species are as follows:

- BSIA population structure - the geographic extent informed by an amalgamation of SSC recommendations for stock status areas and BSIA from Appendix A: Biological Information for the priority species.
- Assessment - the finest scale geographic extent of the species' assessments or sub-area assessments from the most recent assessment.
- NMFS Status Area - the geographic area stratification of stock status determinations that NMFS has made in the past for this species, if applicable.
- ACL Scale - the geographic extent of 2023 ACLs set for the species, or, if applicable, the geographic scale of the ACL for the complex in which it is managed.

The first step was to perform an in-depth scientific literature review for each of the priority species and research prior BSIA assessment endorsements by the SSC to gauge relative biological impacts of alternatives if those stock definitions had the FMP harvest specifications framework applied to them. Appendix A: Biological Information compiles this information for the priority species and is incorporated by reference throughout this analysis. This information was used by analysts to develop conclusory statements found herein.

The second step was to examine the ROA through the lens of MSA and the NS in two subsequent steps. Socioeconomic risks of the action alternatives cannot be directly assessed outside groundfish harvest specifications and management measures process. Therefore, socioeconomic risks are

qualitatively described with regards fairness and equity of allocations in the context of National Standard 4¹⁰. To explore this, the analysis compares action alternatives by running each conceptually through the harvest specifications framework in the FMP to explore whether one alternative may have more or less allocative implications compared to the status quo of the 2023-24 harvest specifications. A stock definition alternative that triggered a need for further allocative action compared to the status quo, may not meet the Purpose and Need. The Purpose and Need limited this action to defining stock boundaries for the priority species for status determination purposes. Allocation was not considered as part of the Purpose and Need. Below we identify whether certain alternatives would require the Council to make future allocation decisions, including during the 2025-2026 harvest specifications process.

The third step was to compare the relative risk of increasing the management burden or having a stock definition and resulting harvest specifications that would differ so much from status quo harvest specifications and management measures that it could considerably increase complexity of (1) Amendment 31 beyond its current scope or (2) the 2025-26 harvest specifications and management measures. Some of these complications may arise from allocation issues created by the stock definition. Some potential implications are so highly speculative, they are not discussed in detail.

Assessors develop the geographic scale of the assessment using multiple factors, including review of scientific information, fishery dependent, and independent data. Assessors can, however, divide geographies as reflection of the available data; however, the assessment(s) results need to be reported to the Council, NMFS, and stakeholders at the same scale as the stock is defined. For example, a single stock, single area species could have three sub-areas based on data availability. Assessors could conduct sub-area assessments representative of the data, but would need to combine the sub-area results to provide results at the stock level, e.g., matching the stock's defined area, for management and status determination. Regarding optimum yield (OY), an assumption is a stocks defined area should be at the scale at which OY can be achieved. It is unclear, under the [2023 Terms of Reference](#), (PFMC, 2022c) if the stock delineation were to not align with the geographic area for which the assessment(s) were conducted, i.e., multiple assessed sub-areas summed to get one assessment result for the stock, if the scale of the aggregate assessment results would provide adequate information relative to achieving OY.

This qualitative comparison of the alternatives, assuming the harvest specifications framework is applied through a separate future action, in Chapter 3 weighs the tradeoffs between **three types of metrics**: biological risks to the species, socioeconomic risks to communities, and management burden. Biological risks may be in the form of localized depletion or the fishery not achieving OY. Socioeconomic risk may be in the form of a lack of fairness and equity of the allocation of harvest privileges or rebuilding restrictions/benefits. Management burden may be a change in management compared to status quo (as characterized by the 2023-24 harvest specifications and management measures (PFMC, 2022a)).

¹⁰ NS4 - Conservation and management measures shall not discriminate between residents of different states.

2. Description of Alternatives

This section describes ROA adopted by the Council at their November 2022 meeting and includes the Alternatives selected as the PPA at their March 2023 meeting.

2.1 Summary of the Alternatives

The ROA includes the No Action alternative and the four action alternatives specified by the Council in November 2022 as well as including sub-alternatives that change the latitude at which stocks would be delineated (Table 2). Each action alternative is considered for a specific set of species. One alternative will be adopted for each species, i.e., multiple alternatives cannot be selected for a single species. In brief, Alternative 1 would define the species as a single stock and status would be determined by its geographic scale. The Alternative number reflects the number of stocks considered under the alternative, e.g., Alternative 1 is for those priority species considered as a single stock; Alternative 2 is for priority species considered two stocks (e.g., north of and south of 40° 10' N. latitude), etc. Alternatives 2-4 the stock would be delineated at a finer scale than coastwide, with status made at the corresponding delineation specified by the alternative.

2.1.1 Range of Alternatives

- **No Action** would not define priority species as stocks in the FMP.
- **Alternative 1** a single stock, single area within the Fishery Management Unit (FMU).
 - **Sub-Alternative 1a**¹¹ considers a single stock with multiple harvest control rules applied to sub-area assessments.
- **Alternative 2** two stocks within the FMU, separated north of and south of 40° 10' N. lat.
 - **Sub-Alternative 2a** two stocks within the FMU, separated north and south of 42° N. lat.; i.e., a Washington and Oregon stock, and a California stock.
- **Alternative 3** three stocks within the FMU, aligned with state boundaries (i.e., a California stock, an Oregon stock, and a Washington stock).
 - **Sub-Alternative 3a** three stocks; a Washington and Oregon stock (north of 42° N. lat.), a northern California stock (between 42° N. lat. and 34° 27' N. lat.), and a southern California stock (south of 34° 27' N. lat.).
- **Alternative 4** four stocks; a Washington stock, an Oregon stock, a northern California stock (north of 34° 27' N. lat.), and a southern California stock (south of 34° 27' N. lat.).

Sub-Alternatives 2a and 3a within the scope of the ROA vary the latitude at which the stocks are delineated, while keeping the number of stocks for the species the same. **Sub-Alternative 1a** within the scope of the ROA considers a change to the harvest specifications framework

¹¹ Sub-Alternative 1a (varying harvest control rules [HCRs] by sub-area assessment) and Sub-Alternative 1b (single HCR per stock) are described in detail in Appendix 2. In this document, Sub-Alternative 1b is subsumed into Alternative 1, as described in Section 2.3.

In March of 2023, the analytical team identified an error in the ROA document. Vermilion rockfish were assessed off of Washington and Oregon; whereas, off of California, the vermilion/sunset rockfish were assessed as a single species. Vermilion and sunset rockfish are largely indistinguishable from one another, and the data does not allow for separation, hence they are treated as a “cryptic species pair” but assessed as a single species. The population’s assessment (Monk et al, 2021) and scientific literature (see Appendix A: Biological Information) for vermilion/sunset rockfish supports that the biogeographical range of vermilion/sunset rockfish appears to be limited to California. Therefore, in the following description of the alternatives, analysts have specified in what geographic delineation vermilion rockfish or vermilion/sunset rockfish would be considered a stock under the alternative.

The alternatives considered for each priority species are detailed below and analyzed in comparative fashion in Chapter 3

2.1.2 Council Adopted PPA and Modifications to the ROA

The Council adopted its PPA and modified the ROA by adding quillback rockfish and vermilion and vermilion/sunset rockfishes to Alternative 2a at its March 2023 meeting.

- Alternative 1 (single stock; single area) was adopted as PPA for canary rockfish, Dover sole, Pacific spiny dogfish, petrale sole, rex sole, sablefish, squarespot rockfish, and shortspine thornyhead;
- Alternative 2 (two stocks; north of and south of 40° 10' N. lat) was adopted as PPA for lingcod ;
- Alternative 2a (two stocks; north and south of 42° N. lat.; i.e., a Washington and Oregon stock, and a California) stock was adopted as PPA for copper rockfish;
- Alternative 3 (three stocks; a California stock, an Oregon stock, and a Washington stock) was adopted as PPA for black and quillback rockfishes.

The Council did not adopt a PPA for vermilion and vermilion/sunset rockfishes. Table 2 provides a summary of the Alternative(s), the species considered, the resulting stock area delineation, the alternatives which the Council has selected as PPA, and the new alternatives for quillback rockfish, and vermilion and vermilion/sunset rockfishes at its March 2023 meeting.

For all the action alternatives, the following applies:

1.) As a direct result of this action, if approved:

- NMFS will determine status of the stock(s) at the geographic scale identified in the Alternative and described in the FMP;
- Stock complexes will not change at this time.

2.) Regarding the next groundfish biennial specifications action (2025-2026 biennial cycle):

- The OFL/ABC/ACL would be calculated and/or set at the same scale as the stock’s geographic delineation (Exception Sub-Alternative 1a). As under current procedures, the ABC/ACL could be further subdivided, but the division would be based on the areal specification;
- The FMP’s harvest specifications framework applies to a stock, and each stock would have a default harvest control rule based on the stock’s estimated depletion (Exception Sub-Alternative 1a);

- For stocks managed in a complex, the OFL/ABC/ACL calculation is apportioned into the stock complex harvest specifications using status quo methods;
- All of the alternatives would allow varying sigma values for sub-area assessments to capture assessment uncertainty.

Table 2. Action alternatives to be analyzed for priority groundfish species. Numbering of Alternatives reflects the number of area delineations considered for the priority species. PPA=Preliminary preferred alternative

Priority Species	Alternative(s)	# of Stocks	Stock Area(s) Delineation
Species considered under a single Alternative			
Canary rockfish	1 (PPA)	One	Single Area
Dover sole	1 (PPA)	One	Single Area
Pacific spiny dogfish	1 (PPA)	One	Single Area
Petrals sole	1 (PPA)	One	Single Area
Rex sole	1 (PPA)	One	Single Area
Sablefish	1 (PPA)	One	Single Area
Shortspine thornyhead	1 (PPA)	One	Single Area
Lingcod	2 (PPA)	Two	N. of 40° 10' N. lat. stock and S. 40° 10' N. lat. stock
Species considered under a multiple Alternatives			
Black rockfish	1	One	Single Area
	3 (PPA)	Three	a Washington stock, an Oregon stock, & a California stock
Quillback Rockfish a/	1	One	Single Area
	2a	Two	a N. of 42° N. lat. stock and a S. 42° N. lat. stock
	3 (PPA)	Three	Washington stock, Oregon stock, & California stock
Squarespot Rockfish	1 (PPA)	One	Single Area
	3	Three	Washington stock, Oregon stock, & California stock
Copper Rockfish a/	1	One	Single Area
	2a (PPA)	Two	N. of 42° N. lat. stock and S. 42° N. lat. stock
	3	Three	Washington stock, Oregon stock, & California stock
Vermilion Rockfish and	1	One	Single Area
	2	Two	N. of 40° 10' N. lat. stock and a S. 40° 10' N. lat. stock

Priority Species	Alternative(s)	# of Stocks	Stock Area(s) Delineation
Vermilion/Sunset Rockfish a/ b/ c/ Vermilion Rockfish and Vermilion/Sunset Rockfish a/ b/ c/	2a	Two	N. of 42° N. lat. vermilion rockfish stock and S. 42° N. lat. vermilion/sunset rockfish stock
	3	Three	Washington vermilion rockfish stock, Oregon vermilion rockfish stock, & California vermilion/sunset rockfish stock
	3a	Three	Washington and Oregon [N. of 42° N. lat.] vermilion rockfish stock, Northern California [north of 34° 27' N. lat.] vermilion/sunset rockfish stock, and Southern California [south of 34° 27' N. lat.] vermilion/sunset rockfish stock
	4	Four	Washington vermilion rockfish stock, Oregon vermilion rockfish stock, Northern California [north of 34° 27' N. lat.] vermilion/sunset rockfish stock, and Southern California [south of 34° 27' N. lat.] vermilion/sunset rockfish stock

a/ Note: New Sub-Alternative 2a for quillback rockfish added by Council in March 2023. Sub-Alternative 2a for copper rockfish per SSC status recommendation ([Agenda Item E.3.a, Supplemental SSC Report 1, November 2021](#)). New Sub-Alternative 2a for vermilion and vermilion/sunset rockfish added by the Council in March 2023.

b/ If Alternative 2 were adopted, a new assessment for vermilion and vermilion/sunset rockfish would need to be performed to determine the overfished status at this geographic scale.

c/ Note: Sub-Alternative 3a for vermilion/sunset rockfish is added per SSC recommendation ([Agenda Item E.3.a, Supplemental SSC Report 1, November 2021](#)). New Sub-Alternative 2a for vermilion and vermilion/sunset rockfish added by the Council in March 2023.

2.2 No Action

Under the No Action alternative, the Council would not adopt stock definitions for the priority species. The FMP would not be amended. Status for the priority species could not be determined. Additionally, under the No Action alternative the Council would reject the Purpose and Need for this action.

2.3 Alternative 1 and 1a - Single Stock

Under Alternative 1, species (or cryptic species pair) are each considered a single stock. Alternative 1 is considered for all priority species, except lingcod.

Canary rockfish, Dover sole, Pacific spiny dogfish, petrale sole, rex sole, sablefish, and shortspine thornyhead are only considered under Alternative 1 because there is no discernable population structure based on BSIA and/or assessment area stratification indicating there is more than one stock.

For all species, the FMPs harvest specifications framework applies at a scale equivalent to the stock, or to the population's geographic extent that was assessed on the U.S. West Coast, which is

coastwide for all Alternative 1 species except squarespot rockfish¹². NMFS would determine status for these species as a single stock. Status determination criteria, such as minimum stock size threshold, and overfishing limits would be applicable at the geographic scale equivalent to the stock.

Black, copper, quillback, vermilion, and vermilion/sunset rockfishes have, and are expected to continue to have, sub-area assessments (see Appendix A: Biological Information).¹³ If defined as a single stock under Alternative 1, each species would need to have their assessments pooled for harvest specifications and status determination. In addition, copper rockfish may have assessments pooled across multiple years (2021 and 2023) for harvest specifications and status determinations under Alternative 1.

The Council's ROA included applying different harvest control rules to individual sub-area assessments for Alternative 1 stocks on an ad hoc basis. In this document, this aspect of the ROA is captured in Sub-Alternative 1a. The initial draft of this document describing the ROA ([Agenda Item F.7, Attachment 1, March 2023](#)) also described a Sub-Alternative 1b. However, after further review, the project team found that Sub-Alternative 1b was indistinguishable from Alternative 1. Therefore, in the main body of this document, Sub-Alternative 1b has been subsumed into Alternative 1. The full discussion of these two Sub-Alternatives 1a and formerly 1b, and the comparison between them, is retained in Appendix B - Differential Harvest Control Rules

Alternative 1 is the Council's PPA for canary rockfish, Dover sole, Pacific spiny dogfish, petrale sole, rex sole, sablefish, and shortspine thornyhead (see Appendix C - Species with only one Alternative Considered).

Alternative 1 is the Council's PPA for squarespot rockfish.

2.4 Alternative 2 and 2a: Two Stocks

Alternative 2 would define each species (or cryptic species pair) as two stocks, north and south of 40°10' N. lat. Alternative 2a would define each species (or cryptic species pair) as two stocks, north and south of 42° N. lat. Lingcod is considered only under Alternative 2 and is expected to continue to have northern and southern assessments in the future and is expected to continue to have northern and southern assessments in the future (See Appendix C - Species with only one Alternative Considered). See Section 3.3, Species-Specific Comparison of Alternatives, for species-specific considerations under these alternatives.

Alternative 2 is considered for vermilion/sunset rockfish and lingcod, such that the FMP would be amended to define each species as two stocks, a stock north of 40°10' N. lat. and a stock south of 40°10' N. lat. (Table 2). A region specific OFL/ABC/ACL would be determined for lingcod and/or vermilion/sunset rockfish north of and south of 40°10' N. lat. NMFS would determine status at the same geographic scale.

¹² Squarespot rockfish was assessed coastwide, but data was only available off of California and the species does not appear to range much north of 40° 10' N. lat.

¹³ Black and quillback rockfishes have been assessed at the state scale. Copper and vermilion/sunset rockfishes were assessed as south of 34° 27' N. lat, north of 34° 27' N. lat., Oregon, and Washington sub-areas. A California-only copper rockfish assessment will be completed in 2023.

Alternative 2 is the Council’s PPA for lingcod (see Appendix C - Species with only one Alternative Considered).

Alternative 2a is considered for quillback rockfish, copper rockfish, vermilion rockfish (north of 42° N. lat.) and vermilion/sunset rockfish (south of 42° N. lat.). If Alternative 2a is adopted, the Oregon and Washington assessments would be pooled for purposes of determining stock status. Under Alternative 2a the sub-area assessment results will be pooled across California, if applicable, to conform to the stock’s delineation. The SSC recommended this delineation (Alternative 2a) for copper rockfish in [Agenda Item E.3.a, Supplemental SSC Report 1, November 2021](#).

Alternative 2a is the Council’s PPA for copper rockfish.

2.5 Alternative 3 and 3a: Three Stocks

boundaries. Each species would have a California stock, an Oregon stock, and a Washington stock. Alternative 3a would also define each of these species (or cryptic species pair) as three stocks, combining Washington and Oregon into single stocks, and with two California stocks, north and south of 34° 27' N. lat. (Northern and Southern California). Alternative 3 is the Council’s PPA for black and quillback rockfishes.

Alternative 3 is considered for black, copper, quillback, squarespot¹⁴, vermilion and vermilion/sunset rockfishes (vermilion rockfish would be defined as separate stocks in Oregon and Washington; whereas vermilion/sunset rockfish would be defined as a stock for California), such that the FMP would be amended to define each as three stocks, delineated by state boundaries (i.e., state-specific stocks).

Alternative 3 is the Council’s PPA for black and quillback rockfishes.

The Council’s PPA matches the delineations of the 2021 assessments for quillback rockfish as well as the 2015 and 2023 assessments for black rockfish.

Copper and vermilion/sunset rockfishes were last assessed with a south of 34° 27' N. lat. (Southern California) sub-area and a north of 34° 27' N. lat. (Northern California) sub-area. In order to define these species as California stocks, the California sub-area assessments would be pooled to calculate a California-specific OFL/ABC/ACL and for purposes of making stock status determinations.

Alternative 3a is only considered for vermilion (Washington and Oregon combined stock) and vermilion/sunset rockfishes (Northern California stock and Southern California stock). The SSC recommended consideration of this delineation in [Agenda Item E.3.a, Supplemental SSC Report 1, November 2021](#).

¹⁴ Under Alternative 3, Squarespot rockfish would have a California-only stock definition, consistent with the 2021 assessed area. Squarespot is found primarily in California and predominantly south of 40° 10' N. lat. This species is uncommon north of California. Therefore, practically, Alternative 1 and Alternative 3 for squarespot are the same, because the assessed area under either alternative is the same. See Appendix A for detail.

2.6 Alternative 4: Four Stocks

Alternative 4 would define a species or cryptic species pair as four stocks. If adopted, Alternative 4 would define vermilion and vermilion/sunset rockfishes as four stocks, as follows: a Washington vermilion rockfish stock, an Oregon vermilion rockfish stock, a northern California vermilion/sunset rockfish stock (north of 34° 27' N. lat.), and a Southern California vermilion/sunset rockfish stock (south of 34° 27' N. lat.). Vermilion rockfish would have stock-specific OFL/ABC/ACLs for two stocks, off Washington and off Oregon. Vermilion/sunset rockfish would have stock-specific OFL/ABC/ACLs for two stocks off California. This four-stock delineation correlates to the 2021 assessment areas (Cope et al., 2021a, 2021b; Dick et al., 2021; Monk et al., 2021). NMFS would determine status at the same geographic scale. This alternative was recommended by the SSC at the November 2022 Council meeting ([Agenda Item H.5.a, Supplemental SSC Report 1, November 2022](#))

Page left blank intentionally

3. Comparison of the Alternatives

This chapter discusses the tradeoffs between **three types of metrics**, biological risks to the species, socioeconomic risks to communities, and management burden, as described in Section 1.5 Analytical Process above and summarized below:

1. Biological risks may be in the form of localized depletion or the fishery not achieving OY.
2. Socioeconomic risk may be in the form of a lack of fairness and equity of the allocation of harvest privileges or rebuilding restrictions/benefits.
3. Management burden may change management compared to status quo or may increase the need for an allocative decision. The status quo is characterized by the 2023-24 harvest specifications and management measures (PFMC, 2022a).

Each species' geographic area stratification of four different indicators is shown, as described in Section 1.5 Analytical Process. The metrics for geographic scale shown are:

- ACL scale
- NMFS' current status determination, if applicable;
- BSIA population structure

For each species with single-area/coastwide assessments, only Alternative 1 is considered because there is no discernable population structure based on BSIA and/or assessment area stratification. For lingcod, only Alternative 2 is considered based on genetic information, which indicated a northern and a southern population structure (see Appendix C - Species with only one Alternative Considered).

The FMP currently uses the terms “species” and “stock” interchangeably in a variety of contexts. A thorough and detailed investigation of the FMP and the underpinning laws and policies was undertaken, and it was concluded that, for all species that are “in the fishery,” the FMPs harvest specifications framework (described in FMP Chapter 4) applies at a scale equivalent to the stock. This interpretation is most aligned with the MSA and National Standard Guidelines and illustrates both the need for the proposed action to define stocks (so that the Council can continue to apply existing frameworks in the FMP), and the largely administrative nature of the proposed action (the Council is already applying this framework, and often at a similar or equivalent scale to the PPA stock definition). Only Alternative 1a considers changes to the applicability of this framework.

3.1 No Action

In the following comparative analysis, the action alternatives are compared amongst themselves and not to the No Action alternative, which is a departure from the norm. In most Council actions, the Action alternatives are compared to the No Action alternative; however, in this case, the No Action alternative would mean the FMP would not be in compliance with the MSA and is an untenable option for the Council to consider. In brief, the No Action alternative is untenable because the Council is required to define groundfish species as stocks in the FMP and, therefore, if the Council were to adopt No Action, the FMP would continue to not align with the MSA and

National Standards. All action alternatives, regardless of species, represent a change from No Action as it would draw the FMP into alignment with the MSA and the National Standards. Further, because stocks are not defined under No Action, the stock definitions under the action alternatives have nothing to compare to.

NMFS has advised the Council, both in writing ([Agenda Item E.3.a, NMFS Report 1, March 2022](#)) and verbally at the March ([Agenda Item E.3](#)), June ([Agenda Item F.4](#)), September ([Agenda Item G.5](#)) and November ([Agenda Item H.5](#)) 2022 Council meetings, that steps must be taken to draw the FMP into compliance with the MSA and the National Standards by defining the groundfish species in need of conservation and management as stocks. If stocks are not defined and delineated on a geographic scale, status cannot be determined. Status determination is a key tenant to NS1 and NMFS must provide this information to Congress. As such, No Action is an untenable option for the Council to adopt as it is out of compliance with the MSA and it does not meet the purpose and need for Amendment 31.

These findings result in an inability to provide a basis for meaningful comparison of No Action with the action alternatives. Therefore, it cannot be compared to the other alternatives the Council is considering under this action. For species where there are multiple alternatives under consideration, the alternatives are compared among themselves in Section 3.2 Species with Multiple Alternatives or Multiple Sub-Area Assessments and are not compared to a No Action alternative. As such, the No Action alternative is not analyzed further.

3.2 Species with Multiple Alternatives or Multiple Sub-Area Assessments

Black, copper, quillback, squarespot, vermilion and vermilion/sunset rockfishes are each considered under multiple alternatives (Table 3). Black and squarespot rockfishes are each considered under Alternative 1 (single stock) and Alternative 3 (state-specific stocks). Copper and quillback rockfishes are each considered under three alternatives: Alternatives 1 (single stock, single area), 2a (stocks north and south of 40° 10' N. lat.), and 3 (state-specific stocks). Vermilion/sunset rockfish is considered under Alternative 1 (single stock), Alternative 2 (stocks north and south of 40° 10' N. lat.), vermilion and vermilion/sunset are considered under Alternative 2a (north and south of 42° N. lat.), Alternative 3 (state-specific stocks), Alternative 3a (Washington and Oregon stock, northern California [north of 34° 27' N. lat.] stock, and southern California [south of 34° 27' N. lat.] stock), and Alternative 4 (Washington stock, Oregon stock, northern California [north of 34° 27' N. lat.] stock, and southern California [south of 34° 27' N. lat.] stock).

As discussed in Attachment 1, November 2022, analysts recommended delineating stock boundaries for these species at a finer geographic scale than coastwide. The rationale for considering these species (black, copper, quillback, vermilion rockfish and vermilion/sunset rockfishes) under different alternatives is multifold. These species show distinct, heterogeneous, population structure which is supported by their past population assessments as well as literature. The delineation of stock structure at a finer scale than coastwide has been recommended by the SSC in the case of these species as well as in instances where there is considerable uncertainty about the stock's structure (e.g. [Agenda Item F.7.a, Supplemental SSC Report 1, March 2023](#)).

Under several alternatives, sub-area assessments (e.g., copper rockfish under Alternative 2a) would be pooled to determine stock status (e.g., not overfished or overfished) and OFL/ABC/ACL

for the stock. If multiple sub-area assessments are conducted for a single stock there is the potential of an overfished declaration being driven by the estimates from one or more of the sub-area assessments if the area represents a large proportion of the stock's biomass. However, the rebuilding plan would apply at the level at which the stock is defined. As noted above, combining assessments can mask areas of localized depletion; whereas, sub-area assessments are more likely to reveal localized depletion.

There may be instances where the Council would consider area specific management measures for species that have their sub-area assessments pooled, for example copper rockfish under Alternative 2a. The FMP allows the Council to implement existing and/or develop new measures to address needs of the fishery. As the Council does at present, the FMP allows the Council to adopt measures specific to area and fishery sector, when appropriate. If it was determined the fishery within the assessed sub-area was in need of management in order to meet overall conservation goals, the Council could act in a variety of ways to address the issue. Examples of management measures range from routine, e.g., inseason action, to area specific measures, e.g., annual catch targets or other harvest specification methods.

Table 3. Alternatives and corresponding stock area delineations for black, copper, quillback, squarespot, vermilion and vermilion/sunset rockfishes. PPA=Preliminary preferred alternative

Species	Alternative	# of Stocks	Stock Area(s) Delineation by Alternative
Black Rockfish	1	One	Single Area
	3 (PPA)	Three	a Washington stock, an Oregon stock, and a California stock
Quillback Rockfish a/	1	One	Single Area
	2a	Two	a N. of 42° N. lat. stock and a S. of 42° N. lat. stock
	3 (PPA)	Three	a Washington stock, an Oregon stock, and a California stock
Squarespot Rockfish	1 (PPA)	One	Single Area
	3	Three	a Washington stock, an Oregon stock, and a California stock
Copper Rockfish a/	1	One	Single Area
	2a (PPA)	Two	a N. of 42° N. lat. stock and a S. 42° N. lat. stock
	3	Three	a Washington stock, an Oregon stock, and a California stock
Vermilion rockfish and Vermilion/Sunset Rockfish a/ b / c/	1	One	Single Area
	2	Two	a N. of 40° 10' N. lat. stock and a S. 40° 10' N. lat. stock
	2a	Two	a N. of 42° N. lat. stock of vermilion rockfish & a S. 42° N. lat. stock of vermilion/sunset rockfish

Species	Alternative	# of Stocks	Stock Area(s) Delineation by Alternative
	3	Three	Washington vermilion rockfish stock; Oregon vermilion rockfish stock; & California vermilion/sunset rockfish stock
	3a	Three	Washington/Oregon vermilion rockfish stock; northern California [north of 34° 27' N. lat.] vermilion/sunset rockfish stock; and Southern California [south of 34° 27' N. lat.] vermilion/sunset rockfish stock
	4	Four	Washington vermilion rockfish stock; Oregon vermilion rockfish stock; Northern California [north of 34° 27' N. lat.] vermilion/sunset rockfish stock; and Southern California [south of 34° 27' N. lat.] vermilion/sunset rockfish stock

a/ New Sub-Alternative 2a for quillback rockfish added by Council in March 2023. Sub-Alternative 2a for copper rockfish per SSC status recommendation ([Agenda Item E.3.a, Supplemental SSC Report 1, November 2021](#)). New Sub-Alternative 2a for vermilion and vermilion/sunset rockfish added by the Council in March 2023.

b/ If Alternative 2 were adopted, a new assessment for vermilion and vermilion/sunset rockfish would need to be performed to determine the overfished status at this geographic scale.

c/ Note: Sub-Alternative 3a for vermilion/sunset rockfish is added by the Project Team per SSC recommendation ([Agenda Item E.3.a, Supplemental SSC Report 1, November 2021](#)).

3.2.1 Species with Multiple Sub-area Assessments

The FMP provides status determination criteria (SDC) for species with Category 1 and 2 assessments (PFMC, 2022a). Category 1 and 2 assessments inform stock status; whereas, Category 3 assessments do not (PFMC, 2022a). Category 1 assessments are those with data-rich quantitative assessments where the OFL is based on F_{MSY} or F_{MSY} proxy from model output. ABC based on P^* buffer.¹⁵ Category 2 assessments are data-moderate where the OFL is derived from model output (or natural mortality).¹⁶ Category 3 assessments are data-limited and the OFL is, generally, derived from historical catch.¹⁷ In some cases, data-moderate assessments can be classified as Category 3 assessments. In April 2023, the project team considered the possibility that a stock may have multiple sub-area assessments (that may include Category 3 assessments) and how that might affect NMFS' ability to make status determinations for each stock under current SDCs in the FMP (Section 4.4.3).

The Category recommendation of a stock assessment is within the purview of the SSC, per the Terms of Reference (TOR) ([PFMC, 2022c](#)). Based on a comprehensive review of Chapter 4 of the FMP, stocks defined by the Council under Amendment 31 should have assessments with a single SSC-endorsed category, such that the harvest specifications framework can be applied to the stock. There are multiple instances where there is not yet a Category endorsement from the SSC for the following alternative stocks considered in the action alternatives within this analysis:

¹⁵ See the FMP, §4.4 (PFMC, 2022a) or Appendix F of PFMC, 2022c for additional detail.

¹⁶ *id.*

¹⁷ *id.*

1. Black, copper, quillback, squarespot, vermilion and vermilion/sunset rockfishes each as single stocks (Alternative 1);
2. Quillback rockfish north of 42° N. lat. (Alternative 2a);
3. Copper rockfish north of 42° N. lat. (Alternative 2a (PPA));
4. Copper rockfish south of 42° N. lat. (Alternative 2a (PPA), and Alternative 3); and
5. Vermilion rockfish north of 42° N. lat. (Alternative 2a) and vermilion/sunset rockfish south of 42° N. lat. (Alternative 2a, 3, 3a).

As described in Section 4.2 of the FMP, three Categories of species assessments are identified. The units at which those Categories are applicable is equivalent to “the stock” for which status determination criteria in the FMP are applied (e.g., MSST, OFL, ACL, rebuilding standards, etc.). The implication of this is that if a stock, as defined by the Council, has multiple assessment areas, a single Category would be assigned by the SSC, per the TOR.

Ideally, a methodology would be developed by the Council’s science advisors or stock assessment teams and approved by the SSC for how to formulate, and ultimately recommend, a single combined Category for a stock that has multiple sub-area assessments. The project team acknowledges that it is not the purview of the SSC to develop such a methodology. There may not be staffing capacity to develop a new holistic and/or broadly applicable methodology in 2023 for SSC endorsement and application to 2021 and 2023 stock assessments.

Analysts recommend that, if the Council chooses a Final Preferred Alternative (FPA) including any of the above alternatives, that they request the SSC advise them regarding the Category for the Council’s FPA stocks that have multiple sub-area assessments. This advice or recommendations from the SSC on Category assignments for 2021 and 2023 assessments could be considered an interim solution until a more robust methodology is developed, which should then be documented in the FMP and other documents (e.g., TOR, etc.) as appropriate.

This is a substantive issue for priority species that have sub-area assessments that are Category 3 (e.g., the Washington state sub-area for quillback rockfish [Langseth et al, 2021] and possibly others in the future). As intimated in FMP in Section 4.4.3, in general, there may not be sufficient data to determine overfished status for Category 3 species. If status for a Category 3 species cannot be determined, a question arises regarding how (or whether) stock status could/should be determined for a stock that contains one or more Category 3 sub-area assessments. Due to the uncertainty regarding status determination and Category 3 species, a discussion among the Council’s science advisors is necessary to resolve this issue no later than at the November 2023 Council meeting so that it is clear how and when an overfished stock status determination can be made by NMFS.

If the SSC does not advise against it, the Council could presume that combining two Category 1 or two Category 2 sub-area assessments, for purposes of estimating depletion, would result in an assessment of the stock to be of an appropriately robust level of information (Category 1 or 2) which would allow NMFS to make overfished stock status determinations.

3.3 Species-Specific Comparison of Alternatives

3.3.1 Species with only one Alternative

Eight of the priority species are considered under a single alternative: canary rockfish, Dover sole, lingcod, Pacific spiny dogfish, petrale sole, rex sole, sablefish, and shortspine thornyhead. The only comparative alternative for these species is the No Action Alternative, which, as discussed in Section 2.2 is untenable and not a meaningful comparison. Therefore, Appendix C - Species with only one Alternative Considered, describes the impact of and rationale for the alternative for each of these species but does not compare them to other alternatives. Given the lack of evidence to support considering other alternatives for these species, no additional alternatives are considered, and no comparisons to the other alternatives can be made.

3.3.2 Canary rockfish, Dover sole, Pacific spiny dogfish, petrale sole, rex sole, sablefish, and shortspine thornyhead: PPA Analysis

Canary rockfish, Dover sole, Pacific spiny dogfish, petrale sole, rex sole, sablefish, and shortspine thornyhead are considered only under Alternative 1. These species have been consistently considered a single population across all metrics evaluated as shown in Table 4 and detailed in Appendix A: Biological Information.

Biological: A detailed literature review, assessment findings, and BSIA indicate these species have no discernible population structure along the West Coast. Genetics, larval dispersal, and/or adult movement data do not support, at present, delineating these species on a finer geographic scale than coastwide basis or as less than a single stock. All of these species have been assessed at the coastwide scale and have historically had single coastwide OFL/ABC/ACLs. The assessments were recommended by the SSC as BSIA, adopted by the Council,¹⁸ and determined as BSIA by NMFS. Further, the SSC recommended the geographic scale of each of these assessments as the scale for status determination¹⁹. Defining these species as stocks at a finer scale than coastwide would require new information. No new information was found in the literature review presented in Appendix A: Biological Information.

Socioeconomic: Alternative 1 is most similar to the current geographic scale of harvest specifications and management measures for canary rockfish, Dover sole, Pacific spiny dogfish, petrale sole, and rex sole and is unlikely to trigger allocation/apportionment issues since it aligns with current management.

¹⁸ See [Agenda Item G.5.a, Supplemental SSC Report 1, June 2021](#) for Dover sole and sablefish. See [Agenda Item D.8.a, Supplemental SSC Report 1, June 2015](#) for Canary rockfish; see [Agenda Item F.5.a, Supplemental SSC Report, June 2015](#) for rex sole; see [Agenda Item G.3.a, Supplemental SSC Report, Sept 2013](#) shortspine thornyhead; see [Agenda Item E.2.a, Supplemental SSC Report 1, November 2021](#) for Pacific spiny dogfish

¹⁹ *Id.*

The ACL scale for sablefish²⁰ and shortspine thornyhead²¹ is apportioned on a smaller scale than coastwide, consistent with the geographic scale of their respective allocations in the FMP. There are unlikely to be many potential socioeconomic risks associated with either Alternative 1 regarding inequitable allocation of the resource among states unless the species’ distribution changes as Alternative 1 stock definitions would not alter current management or allocation policies for these species.

Alternative 1 may be less likely to change socioeconomic impacts on coastal communities due to allocation policy changes compared to the 2023-24 biennial cycle. The Council’s recommendations for the 2023-24 harvest specifications (PFMCA, 2022) have already made equitable allocation of the resource among states. Therefore, Alternative 1 is more likely to be fair and equitable, even without further allocative action.

Management: Alternative 1 is unlikely to require the Council to consider changes to management changes, such as formal or informal allocations, for these species during the 2025-26 harvest specifications and management measures process, which could be potentially controversial, as with any allocative action. Therefore, Alternative 1 presents few new management implications.

PPA: Alternative 1 would define these priority species as single stocks with a geographic range set as the U.S. West Coast. A single stock definition is appropriate when sufficient mixing occurs and harvest in one area could affect the trajectory of the stock in all areas. Status determinations for these stocks would be at the coastwide scale. Alternative 1 is the most consistent within the regulatory framework for these species. Alternative 1 was recommended by the GMT ([Agenda Item F.7.a, Supplemental GMT Report 1, March 2023](#)), GAP ([Agenda Item F.7.a, Supplemental REVISED version 2 GAP Report 1, March 2023](#)), and the SSC ([Agenda Item F.7.a, Supplemental SSC Report 1, March 2023](#)).

Summary – These species have consistently been delineated as coastwide across all metrics evaluated (Table 4). Alternative 1 is least likely to have increased biological risks, socioeconomic risks, and management burden.

Table 4. Comparison of the Council recommended Preliminary Preferred Alternative (PPA) to the annual catch limit (ACL) scale of species, NMFS status area, scientific and statistical committee (SSC) recommendation for population structure, and the most recent assessment, for species with only a single alternative (Alternative 1) considered (see Section 1.5).

Species	PPA Alternative 1 Stock Delineation	ACL Scale	NMFS Status Area	SSC Pop. Structure Recommendation	Assessment and Year
Canary Rockfish	Coastwide	Coastwide	Pacific Coast	Single Stock	Coastwide (2015) b/

²⁰ For sablefish, a coastwide assessment is conducted. From the assessment, by application of the harvest specifications framework in the FMP, a coastwide ACL is calculated using a coastwide ACL control rule and then the ACL is apportioned north and south, so that formal allocation structures can be applied, consistent with the FMP.

²¹ For shortspine thornyhead a coastwide assessment is conducted. In the 2023-24 groundfish harvest specifications and management measure process the coastwide ABC was apportioned N./S. of 34° 27' N. lat. and the ACL for each area was set equal to the ABC.

Species	PPA Alternative 1 Stock Delineation	ACL Scale	NMFS Status Area	SSC Pop. Structure Recommendation	Assessment and Year
Dover Sole	Coastwide	Coastwide	Pacific Coast	Single Stock	Coastwide (2021)
Pacific Spiny Dogfish	Coastwide	Coastwide	Pacific Coast	Single Stock	Coastwide (2021)
Petrале Sole	Coastwide	Coastwide	Pacific Coast	Single Stock	Coastwide (2019)
Rex Sole	Coastwide	Coastwide	Pacific Coast	Single Stock	Coastwide (2013) b/
Sablefish a/	Coastwide	N. of 36° N. lat.	Pacific Coast	Single Stock	Coastwide (2019)
		S. of 36° N. lat.			
Shortspine Thornyhead a/	Coastwide	N. of 34° 27' N. lat.	Pacific Coast	Single Stock	Coastwide (2013) b/
		S. of 34° 27' N. lat.			

a/ Geographic area of the ACL has been specified within the allocation framework of the FMP.

b/ Canary rockfish, rex sole, and shortspine thornyhead are to be reassessed in 2023.

3.3.3 Lingcod: PPA Analysis

Lingcod is considered only under Alternative 2. This species is consistently stratified into two geographical regions across all metrics evaluated (Table 5). Alternative 2 would define lingcod as two (N./S. of 40° 10' N. lat.) stocks with the OFL/ABC/ACLs set at that geographic scale.

Biological: Alternative 2 reflects the current understanding of lingcod population biology. Lingcod exhibit distinct population structure north and south of 40° 10' N. latitude. (Longo et al., 2020). This biogeographic split was used as the basis for the most recent assessments (Johnson et al., 2021; Taylor et al., 2021). Available literature and assessment findings for lingcod supports the bi-regional stock definition. The SSC recommended the assessments as BSIA as well as the geographic scale for status determination ([Agenda Item C.6.a, Supplemental SSC Report 1, Sept. 2021](#)).

Table 5. Comparison of the Council recommended Preliminary Preferred Alternative (PPA) to the annual catch limit (ACL) scale of species, NMFS status area, scientific and statistical committee (SSC) recommendation for population (Pop) structure recommendation, and the most recent assessment for lingcod. North = N, South = S.

Species	PPA: Alternative 2 Stock Delineations	ACL Scale	NMFS Status Area	SSC Pop. Structure Recommendation	Assessment Area & Year
Lingcod	N. of 40° 10' N. lat.	N. of 40° 10' N. lat.	N. Pacific Coast	N. of 40° 10' N. lat.	N. of 40° 10' N. lat. (2021)
	S. of 40° 10' N. lat.	S. of 40° 10' N. lat.	S. Pacific Coast	S. of 40° 10' N. lat.	S. of 40° 10' N. lat. (2021)

Socioeconomic: Alternative 2 is unlikely to require the Council to consider changes to management, such as formal or informal allocations, for this species during the 2025-26 harvest specifications and management measures process, which could be potentially controversial, as with any allocative action. Therefore, Alternative 1 presents few new management implications.

Management: Lingcod harvest specifications and management measures have historically been set at those regional scales. Alternative 2 is consistent with current harvest specifications and management measures. Alternative 2 is not likely to increase management burden or complexity as lingcod is managed in this manner at present. Impacts of an Alternative 2 stock definition are expected to be consistent with the 2023-24 harvest specifications and management measures (PFMC, 2022a).

Summary – Lingcod has consistently been delineated at north and south of 40° 10' N. latitude across all metrics evaluated (Table 5). Alternative 2 is least likely to have increased biological, socioeconomic risks, and management burden.

PPA: The Council recommended Alternative 2 for lingcod, which would define lingcod as two stocks, one north of and one south of 40° 10' N. lat. Status for these stocks would be at the same scale. Alternative 2 is the most consistent within the regulatory framework for these species. Alternative 2 was recommended by the GMT ([Agenda Item F.7.a, Supplemental GMT Report 1, March 2023](#)), GAP ([Agenda Item F.7.a, Supplemental REVISED version 2 GAP Report 1, March 2023](#)), and the SSC ([Agenda Item F.7.a, Supplemental SSC Report 1, March 2023](#)).

3.3.4 Black Rockfish PPA Analysis

Black rockfish was last assessed in 2015 and is being reassessed in 2023. The SSC and NMFS endorsed the 2015 three sub-area state assessment model as BSIA and recommended a state-specific geographic scale for determining status ([Agenda Item I.3.a, Supplemental SSC Report 1, November 2015](#)). Black rockfish is considered under Alternative 1 (single stock) and Alternative 3 (three stocks, PPA) as shown in Table 3. Black rockfish has consistently been delineated by state boundaries across all metrics evaluated (Table 6).

Table 6. Comparison of the Council recommended Preliminary Preferred Alternative (PPA) to the annual catch limit (ACL) scale of species, NMFS status area, scientific and statistical committee (SSC) recommendation for population (Pop) structure recommendation, and the most recent assessment for black rockfish.

Species	PPA: Alternative 3 Stock Delineations	ACL Scale	NMFS Status Area	SSC Pop. Structure Recommendation	Assessment Area & Year
Black Rockfish	Washington	Washington	Washington	Washington	Washington (2015)
	Oregon	Oregon	Oregon	Oregon	Oregon (2015)
	California	California	California	California	California (2015)

a/ black rockfish is being reassessed for each of the three states in 2023.

Biological - Current BSIA, literature, and assessments support the finding that black rockfish has distinct population structure (Appendix A: Biological Information). Alternative 3 would define the

species as three stocks that align with state boundaries and status would be determined at the same scale. Alternative 3 aligns with BSIA, recognizing this species has population structure on a finer scale than coastwide. The black rockfish state-specific assessments are representative of regional dynamics that align with potential state-specific population structure for this species. Therefore, Alternative 3 is least likely of the two alternatives to have negative biological implications within the context of the harvest specifications framework in the FMP. Status determination at the same scale as the assessment under Alternative 3 are more likely to be representative of region-based status.

Socioeconomic - Alternative 3 is most similar to the current geographic scale of black rockfish harvest specifications and management measures and is unlikely to trigger allocation/apportionment issues since it aligns with current management. Alternative 3 may be less likely to change socioeconomic impacts on coastal communities due to allocation policy changes compared to the 2023-24 biennial cycle. The Council's recommendations for the 2023-24 harvest specifications (PFMCA, 2022) have already made equitable allocation of the resource among states. Therefore, Alternative 3 is more likely to be fair and equitable without further allocative actions.

Management - As discussed above, Alternative 3 is unlikely to increase the need for inter-state allocative decisions of black rockfish. Alternative 3 is unlikely to require the Council to consider a formal or informal allocation of black rockfish during the 2025-26 harvest specifications and management measures process, which could be potentially controversial, as with any allocative action. Therefore, Alternative 3 presents few new management implications.

Other considerations - Alternative 1 would specify a single OFL/ABC/ACL for the black rockfish stock. Harvest specifications for black rockfish off Oregon would need to be apportioned and would contribute to the Black/Blue/Deacon Rockfish Complex harvest specifications. It is currently unclear how the calculation of harvest specifications would be accomplished, in a manner consistent with the harvest specifications framework in the FMP, if black rockfish were defined as a single stock under Alternative 1 and remained in a stock complex off the coast of Oregon. Defining black rockfish as a single stock under Alternative 1, while leaving it managed in a complex in a portion of its range, appears to perpetuate the mismatch in scale between overfished determinations (all sub-area assessments combined) and overfishing determinations (scale at which the stocks OFL is set).

Summary - Black rockfish has consistently been delineated by state boundaries across all metrics evaluated (Table 6). Alternative 3 is least likely to have increased biological, socioeconomic risks, and management burden.

PPA – The Council recommended a PPA stock definition for black rockfish of three state-specific stocks (Alternative 3). Alternative 3 best captures the scientific information indicating that there may be insufficient mixing across the species' range to support a single stock definition. Alternative 3 also best fits within the regulatory framework that black rockfish are currently managed under. Alternative 3 was also recommended by the GMT ([Agenda Item F.7.a, Supplemental GMT Report 1, March 2023](#)), GAP ([Agenda Item F.7.a, Supplemental REVISED version 2 GAP Report 1, March 2023](#)), and the SSC ([Agenda Item F.7.a, Supplemental SSC Report 1, March 2023](#)).

3.3.5 Copper rockfish: PPA Analysis

Copper rockfish was last assessed in 2021 with four sub-areas: Washington, Oregon, California N of north of 34° 27' N. lat. and California: S of north of 34° 27' N. lat. In 2023, a copper rockfish is being assessed for California N of north of 34° 27' N. lat. and California: south of 34° 27' N. lat. is being completed at the same scale as 2021. Copper rockfish is considered under Alternative 1 (single stock), Alternative 2a (two stocks N/S of 42° N. lat.), and Alternative 3 (three state-specific stock) as shown above in Table 3. The SSC has endorsed four area assessment models of copper rockfish in 2021 as BSIA ([Agenda Item C.6.a, Supplemental SSC Report 1, September 2021](#)). However, the SSC recommended a reduction to two stock areas (north and south of 42° N. lat.) for status determination and to pool the biomass estimates from the Southern and Northern California assessments and pooling the biomass for Oregon and Washington ([Agenda Item E.3.a, Supplemental SSC Report 1, November 2021](#)) to determine status in California and Washington & Oregon, respectively. Copper rockfish has been delineated at less than coastwide across three out of the four evaluated metrics (Table 7).

Table 7: Comparison of the Council recommended Preliminary Preferred Alternative (PPA) to the annual catch limit (ACL) scale of species, NMFS status area, scientific and statistical committee (SSC) recommendation for population (Pop) structure recommendation, and the most recent assessment, for copper rockfish. North = “N.” and South = “S.”

Species	PPA: Alternative 2a Stock Delineations	ACL Scale	NMFS Status Area	SSC Pop. Structure Recommendation	Assessment Area & Year
Copper Rockfish	N. of 42° N. lat. stock	Nearshore Rockfish Complex: North of 40° 10' N. lat.	Pacific Coast a/	WA/OR (North of 42° N. lat.)	Washington (2021)
					Oregon (2021)
	S. of 42° N. lat. stock	Nearshore Rockfish Complex South of 40° 10' N. lat.		CA (South of 42° N. lat.)	California N. of 34° 27' N. lat. (2021)
					California S. of 34° 27' N. lat. (2021)

a/ Note: NMFS made a “not overfished” status determination for “copper rockfish - Pacific Coast” based on the 2013 assessment, though catches since that time have doubled. The 2013 assessment also assumed a more optimistic status in 2013 than was found in the 2021 stock assessment.

distinct population structure at a finer geographic scale than coastwide (Appendix A: Biological Information). Both Alternative 2a and Alternative 3 would be consistent with that finding. These alternatives are both consistent with BSIA as they both reflect a population structure at a finer scale than coastwide. If copper rockfish assessments are pooled into a regional (Alternative 2a) or state-specific (Alternative 3) stock, they are more likely to be representative of regional dynamics and the species population structure compared to Alternative 1. Therefore, Alternatives 2a and 3 are least likely of the three alternatives to have negative biological implications within the context of the harvest specifications framework in the FMP. Alternative 1 has a higher risk of resulting in a combined coastwide status determination that may not be reflective of differences in localized population dynamics (e.g., localized depletion, exploitation history, etc.). Therefore, Alternative 1

is more likely than Alternatives 2a or 3 to have biological implications within the context of the harvest specifications framework in the FMP. Further, Alternative 2a is at an equivalent geographic delineation as the SSC recommendation for the species ([Agenda Item E.3.a, Supplemental SSC Report 1, November 2021](#)). Currently, it is unclear whether there is any distinguishable difference between Alternatives 2a and 3 with regards to biological risks. Alternative 3 is more likely to be representative of region-based status than Alternative 1 or Alternative 2a. Alternative 1 has a higher risk of resulting in a combined coastwide status determination that may not be reflective of differences in localized population dynamics (e.g., localized depletion, exploitation history, etc.). Therefore, Alternative 1 is more likely than Alternative 3 or Alternative 2a to have biological implications within the context of the harvest specifications framework in the FMP. Similarly, Alternative 2a is more likely than Alternative 3 to have biological implications within the context of the harvest specifications framework in the FMP.

Socioeconomic - Alternative 2a and 3 are expected to not appreciably change socioeconomic risks regarding equitable allocations compared to Alternative 1. Alternative 1 could increase socioeconomic risks compared to Alternatives 2a and 3 if region-specific or state-specific allocations are necessary. Alternatives 1, 2a, and 3 have decreasing risk of allocations being unfair and inequitable, with Alternative 1 having the highest risk and Alternative 3 having the lowest risk. In other words, Alternatives 1 and 2a may have a higher management burden to establish fair and equitable allocations among the states than Alternative 3. Should formal or informal allocation/apportionment be necessary as a result of Alternatives 1 or 2a, socioeconomic impacts on fishing communities could change based on the outcome of that allocation process. Alternatives 2a and 3 are less likely to change socioeconomic impacts on coastal communities due to allocation policy changes compared to the 2023-24 biennial cycle. The Council's recommendations for the 2023-24 harvest specifications and management measures have already made equitable allocation of the resource among states, therefore Alternatives 2a and 3 are most likely to be fair and equitable without further allocative actions.

Management - As discussed above, Alternative 1 may increase the need for allocative decisions regarding regional or state-specific allocations or harvest shares of copper rockfish compared to Alternatives 2a or 3. Such increase might require the Council to consider a formal or informal allocation of copper rockfish during the 2025-26 harvest specifications and management measures process, which could be potentially controversial, as with any allocative action. Therefore, Alternative 1 and Alternative 2a might have a higher management burden than Alternative 3 since state-specific harvest shares are calculated by assessments under status quo management. As noted above, combining assessments can mask areas of localized depletion; whereas, sub-area assessments are more likely to reveal localized depletion.

Other considerations - If the Council continued to manage the species within the nearshore rockfish complexes, Figure 2 and Figure 3 show potential pathways to accomplish the harvest specifications calculation, consistent with the current harvest specifications framework in the FMP, for Alternative 2a (PPA) and Alternative 3, respectively. Each model would estimate an OFL contribution. Then a singular P^* for each stock area and the SSC-recommended sigma which would be applied for each sub-area assessment. Then the sub-area assessment ABCs for each stock would be summed. To each stocks' ABC a single ACL control rule would be applied to calculate the ACL contribution. Alternative 2a and 3 presume that combining results of two Category 2 sub-

area assessments would result in a stock assessment robust enough to determine overfished status of the stocks north of 42° N. lat. (Alt 2a) and south of 42° N. lat. (Alt. 2a and 3) (i.e., Category of the stock assessments remain Category 2).

Summary - Copper rockfish has consistently been delineated at a less than coastwide scale across three out of the four metrics evaluated (Table 7). Alternative 2a is most aligned with BSIA. Alternative 3 is least likely to require allocative decisions to mitigate socioeconomic or management impacts. However, both Alternative 2a and 3 raise a practical question of assigning an assessment a Category when two or more sub-area assessments are combined. Until the Council adopts a formal definition and the stock(s) are assessed, complexity of management is highly uncertain.

PPA – The Council recommended a PPA stock definition for copper rockfish of two stocks, delineated at the Oregon/California border, i.e., north and south of 42° N. lat. stock (Alternative 2a). Alternative 2a or Alternative 3 best capture the scientific information indicating that there may be insufficient mixing across the species’ range to support a single stock definition. Alternative 2a is at a very similar geographic scale as the two stock complexes to which copper rockfish contributes harvest specifications. The Council is expected to continue to use management measures to address concerns of localized depletion at the geographic scale of sub-area assessments of the stock, as needed.

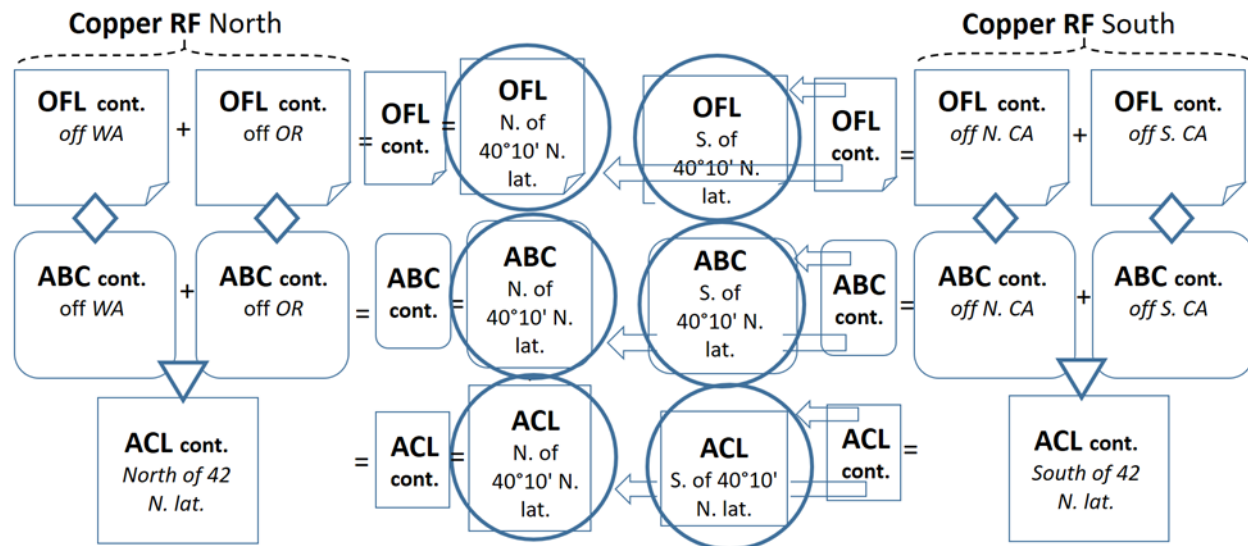

Figure 2. Illustration of harvest specifications calculation methods (i.e., harvest control rules) for copper rockfish (also applicable to vermilion and vermilion/sunset rockfishes) under Alternative 2a – PPA with four assessment units and when managed in a rockfish stock complex. The hashed bracket represents the stock for which overfished status would be determined under Alternative 2a, the diamond represents sigma/P*, triangle represents the ACL control rule, and arrows represent apportionments. Circles indicate values that are specified in regulations (for informational purposes).

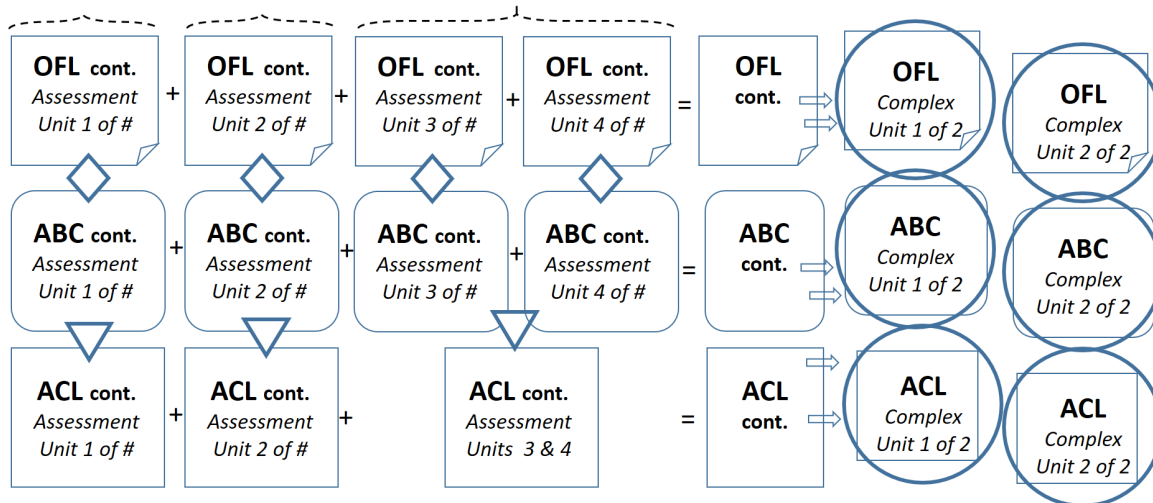

Figure 3. Illustration of harvest specifications calculation methods (i.e., harvest control rules) for copper, vermilion, and vermilion/sunset rockfishes under Alternative 3 or 3a with four assessment units and managed in a rockfish stock complex. The hashed bracket represents the stock for which overfished status would be determined under Alternative 3, the diamond represents sigma/P*, triangle represents the ACL control rule, and arrows represent apportionments. Circles indicate values that are specified in regulations (for informational purposes).

3.3.6 Quillback rockfish: PPA Analysis

Quillback rockfish was last assessed in 2021 with three sub-area assessments at the state level (Langseth et al., 2021). Quillback rockfish is considered under Alternative 1 (single stock), the new Alternative 2a (two stocks N/S of 42° N. lat.)²², and Alternative 3 (three state-specific stocks, PPA) as shown above in Table 2.

The Council adopted a new alternative for quillback rockfish in March 2023, Alternative 2a which would define quillback rockfish as a stock north of 42° N. lat. and a stock 42° N. lat. This Alternative was not evaluated as part of the ROA analysis ([F.7, Attachment 1, March 2023](#)) but is analyzed below by comparing it to Alternative 1 and Alternative 3 (PPA).

The SSC and NMFS endorsed the three state sub-area quillback rockfish assessment model as BSIA ([Agenda Item C.6.a, Supplemental SSC Report 1, September 2021](#)) and recommended a state-specific geographic scale for determining status ([Agenda Item E.3.a, Supplemental SSC Report 1, November 2021](#)). Quillback rockfish has been consistently delineated at less than coastwide across all indicators (Table 8).

²² Added to ROA in March 2023

Table 8. Comparison of the Council recommended Preliminary Preferred Alternative (PPA) to the annual catch limit (ACL) scale of species, NMFS status area, scientific and statistical committee (SSC) recommendation for population (Pop) structure recommendation, and the most recent assessment, for quillback rockfish.

Species	PPA Alternative 3 Stock Delineations	Geographic Factors of Population			
		ACL Scale	NMFS Status area(s)	SSC Pop. structure recommendation	Assessment Area & Year a/
Quillback Rockfish	Washington	Washington	a/	Washington	Washington (2021)
	Oregon	Oregon		Oregon	Oregon (2021)
	California	California		California	California (2021)

a/ Overfished or overfishing status was “unknown”, as of [June 2022 \(NMFS 2022\)](#).

Biological - Current BSIA, literature, and area assessments support the finding that quillback rockfish has a population structure at a finer geographic scale than coastwide (Appendix A: Biological Information). Both Alternative 2a and 3 recognize this species has population structure on a smaller geographic scale than coastwide. Alternative 3 most closely aligns with BSIA. The quillback rockfish state-specific assessments are representative of regional dynamics that align with state-specific population structure for this species. Therefore, Alternative 3 is least likely of the two alternatives to have negative biological implications within the context of the harvest specifications framework in the FMP. Status determination at the same scale as the assessment under Alternative 3 is more likely to be representative of region-based status than Alternative 1 or Alternative 2a.

The 2021 sub-area assessment of quillback rockfish in Washington was classified as a Category 3 assessment. Category 3 assessments are not used to estimate status, per the FMP. The California and Oregon assessments were assigned a Category 2 and can be used to estimate status. This issue raises an important point regarding pooling assessments for any species (see Section 3.2.1), with regards to Alternative 1, Alternative 2a and Alternative 3a. If the Council adopted Alternative 1 or Alternative 2a stock definition for quillback rockfish, there is a question of whether combining Category 3 and Category 2 assessments results in a stock assessment that meets the criteria in the FMP as being appropriate for NMFS’ status determinations. This question is discussed above at Section 3.2.1 and should be considered by the Council’s science advisors.

The Category 3 classification is due, in part, to Washington’s prohibition of a commercial nearshore fishery and so there is less at-sea observer data available to inform sub-area assessments for this species off Washington compared to off of Oregon and California. This is generally true for all nearshore rockfish.

Socioeconomic - Quillback rockfish does not have harvest specifications at the state scale (Alternative 3) at present, the harvest specifications are apportioned via the nearshore rockfish complexes methods (PFMC, 2022b). Each state manages this species with state level management measures, though the management measures are designed to achieve, but not exceed, quillback rockfish OFL contributions to the nearshore rockfish complexes.

Under Alternative 3, the smaller geographic scale of state delineated stocks for quillback rockfish would likely result in localized (i.e., state-specific) socioeconomic impacts due to future

management actions. It is the least likely of the three alternatives considered to require allocative management measures in the future.

Alternative 2a has a lower risk of state-specific allocative management measures, if considered in a subsequent action, being less fair and equitable than Alternative 1, but perhaps higher risk than Alternative 3.

Alternative 1 has a greater risk of state-specific allocations being less fair and equitable compared to Alternative 3 because state-specific shares from state-specific assessments would not be binding. Should formal or informal allocation/apportionment be necessary as a result of Alternative 1 or Alternative 2a, socioeconomic impacts on fishing communities could change based on the outcome of that allocation process.

Management - Quillback rockfish is managed within the nearshore rockfish complexes north and south of 40° 10' N. lat. at present. Under all alternatives, the Council could continue to apportion the harvest specifications based on previously adopted methods. Alternative 2a is the most geographically similar to current harvest specifications. Alternative 3 is the most geographically similar to current management. In the last biennial cycle, the Council pooled the three state assessments and apportioned the OFL to the nearshore rockfish complexes north and south of 40° 10' N. lat. Alternative 3 infuses independence for separate harvest control rules for state specific harvest specifications. Under Alternative 2a, Washington and Oregon would have a single harvest control rule to set the harvest specifications and the two states need to manage this species in close coordination; whereas, California would have a single harvest control rule to set harvest specifications .

As discussed above in Socioeconomic, Alternative 1 may increase the need for inter-state allocative decisions of quillback rockfish compared to Alternative 2a or Alternative 3. Such increase might require the Council to consider a formal or informal allocation during the 2025-26 harvest specifications and management measures process, which could be potentially controversial, as with any allocative action. Therefore, Alternative 1 might have a higher management burden than Alternative 3 since this species is not managed as a single unit at present.

Other considerations - Quillback rockfish was last assessed across multiple sub-areas at the state scale (Langseth et al., 2021), which aligns with the area stratifications of the stock definitions under Alternative 3. Managing quillback rockfish within the nearshore rockfish complex means the assessments would be pooled, then the OFL/ABC/ACL apportioned to the nearshore rockfish complexes north and south of 40° 10' N. lat. As shown in Figure 4, if quillback rockfish were defined as three stocks (Alternative 3) each would each have their own OFL/ABC/ACL contribution, σ/P^* , and ACL control rule, all combined and then apportioned into the nearshore rockfish complexes north and south of 40° 10' N. lat.

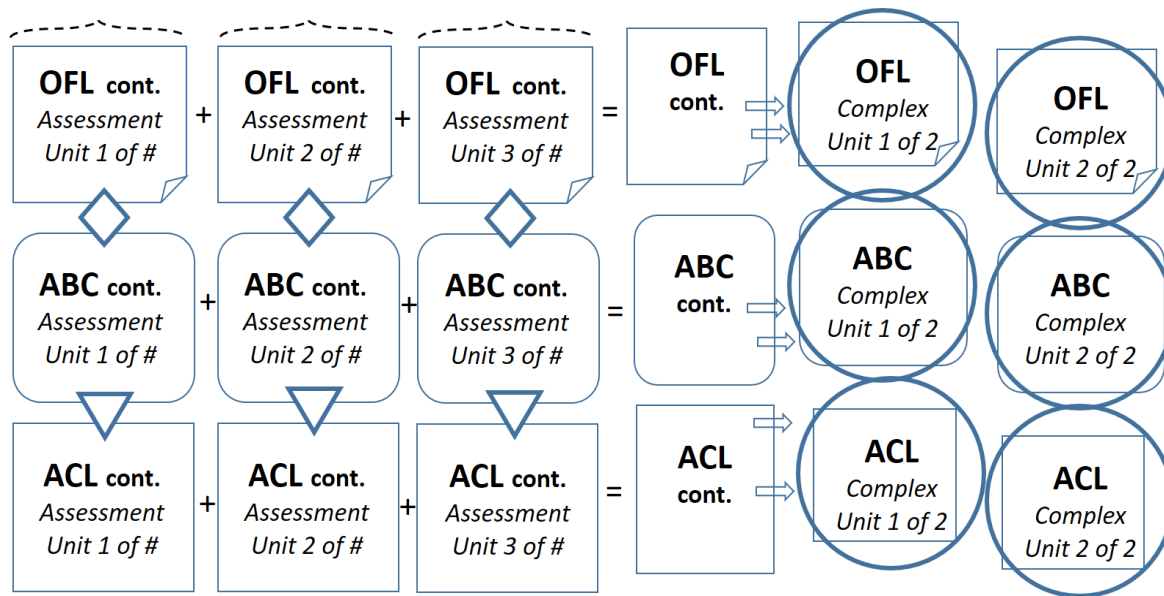

Figure 4. Illustration of harvest specifications calculation methods (i.e., harvest control rules) for quillback rockfish (Alternative 3-PPA). The hashed bracket represents the stock for which overfished status would be determined under Alternative 3, the diamond represents σ/P^* , triangle represents the ACL control rule, and arrows represent apportionments. Circles indicate values that are specified in regulations (for informational purposes). Left and center columns show contributions (cont.) for calculating those harvest specifications.

Summary - Quillback rockfish has been consistently delineated at less than coastwide across all known indicators (Table 8). Alternative 3 and Sub-alternative 1a may result in similar ACL calculations; however, Alternative 1 (single stock) is more likely to have increased biological, socioeconomic risks, and allocative management burden compared to Alternative 3.

PPA – The Council recommended a PPA stock definition for quillback rockfish of state-specific stocks (Alternative 3), for the same reasons presented for black rockfish.

3.3.7 Squarespot rockfish: PPA Analysis

Squarespot rockfish was assessed in 2021 with information available off of California only (Cope et al, 2021). Squarespot rockfish is considered under Alternative 1 (single stock, PPA) and Alternative 3 (State-Specific stock) Table 3. While distributed from southern Oregon to the U.S./Mexico border, the predominant fishery information is from south of Pt. Conception. The SSC and NMFS endorsed the squarespot rockfish assessment’s single state assessment model as BSIA and recommended it for determining status ([Agenda Item C.6.a, Supplemental SSC Report 1, November 2021](#)). Squarespot rockfish has consistently been delineated at a finer geographic scale than coastwide (Table 9).

Table 9. Comparison of the Council recommended Preliminary Preferred Alternative (PPA) to the annual catch limit (ACL) scale of species, NMFS status area, scientific and statistical committee (SSC) recommendation for population (Pop) structure recommendation, and the most recent assessment for squarespot rockfish. North = N and South = S.

Species	PPA Alternative 1 Stock Delineations	Geographic Factors of Population			
		ACL Scale	NMFS Status area	SSC Pop. structure recommendation	Assessment Area & Year
Squarespot Rockfish	Coastwide	Shelf Rockfish Complex North of 40° 10' N. lat. a/	b/	California	California (2021)
		Shelf Rockfish Complex South of 40° 10' N. lat.			

a/ Zero metric ton contribution to complex harvest specifications in this area in 2023

b/ Overfished or overfishing status was “unknown”, as of [June 2022 \(NMFS 2022\)](#).

Biological - Current BSIA, literature, and assessments indicate squarespot rockfish has no discernible population structure and is likely a single stock (Appendix A: Biological Information). Defining this species under Alternative 1 as a single stock would be consistent with BSIA and literature. The primary biomass for squarespot rockfish is south of 40° 10' N. lat., though they are encountered north of California on occasion (Erickson, 1991; RecFIN data, December 2022).

Alternative 1 recognizes this species does not have population structure and the assessment is representative of regional dynamics that align with potential single population structure for this species. For these reasons, Alternative 1 is less likely to reflect the population biology of the species than Alternative 3, as squarespot rockfish do not appear to have populations in Oregon or Washington.

Socioeconomic - Both Alternative 1 and Alternative 3 are expected to have similar socioeconomic impacts. The primary catch of this species is predominantly in California, south of 40° 10' N. lat. It is not a highly sought-after species in commercial fisheries but the Commercial Passenger Fishing Vessel recreational fishery in California commonly encounters them in the southern part of the state (RecFIN and Meritt McRae, pers. comm, Sept 2021).²³ There are unlikely to be many potential **socioeconomic risks** associated with either Alternative 1 or 3 regarding inequitable allocation of the resource among states unless the species’ distribution changes.

Management - At present and in the near term, there is unlikely to be enough information to assess squarespot off Oregon or Washington. Therefore OFL/ABC/ACL under Alternative 1 would be coastwide values informed by California estimates only. It is unlikely that this could impact management burden.

Other Considerations - Under either alternative, it is assumed the Council would continue to manage this species within the Shelf Rockfish Complexes and squarespot rockfish OFL/ABC/ACL off California would contribute to the Shelf Rockfish Complex harvest

²³ RecFIN (data download 5/1/2023) indicates less than 1 percent of squarespot rockfish catch occurs north of 40° 10' N. lat. between 2013-2022

specifications. Based on the 2021 assessment, under either alternative, a single OFL/ABC/ACL would be apportioned to the southern Shelf Rockfish Complex.

Summary - Squarespot rockfish has no discernible population structure and has consistently been delineated at a finer geographic scale less than coastwide across all evaluated metrics (Table 9). However, these delineations are not likely indicative of population structure, but rather more likely because the predominant range of the species is less than coastwide. Alternative 3 and Alternative 1 are likely to result in similar ACL calculations.

PPA – For the reasons described above, the Council recommended a PPA stock definition for squarespot rockfish as a single stock (Alternative 1).

3.3.8 Vermilion and vermilion/sunset rockfish

Vermilion and the vermilion/sunset rockfish cryptic species pair were last assessed in 2021 with four subareas – Washington, Oregon, California north of 42° N. lat., and California south of 42° N. lat. The SSC endorsed the four area assessment models in 2021 as BSIA ([Agenda Item C.6.a, Supplemental SSC Report 1, September 2021](#)). Vermilion and vermilion/sunset rockfish are considered under Alternative 1 (single stock), Alternative 2 (north/south of 40° 10' N. lat. stocks), Alternative 2a (north/south of 42° N. lat. stocks), Alternative 3 (state-specific stocks), Alternative 3a (an Oregon & Washington vermilion rockfish stock, two vermilion/sunset rockfish California stocks (north and south of 34° 27' N. lat.)), and Alternative 4 (as described in Section 2.6), all shown in Table 3. The Council did not adopt a PPA for these species.

The Council adopted a new alternative for vermilion and vermilion/sunset rockfishes in March 2023. Alternative 2a would define the cryptic species pair of vermilion and sunset rockfishes similar to how they were assessed. Under Alternative 2a, vermilion rockfish would be defined as a stock north of 42° N. lat. and vermilion/sunset rockfish would be defined as a stock south of 42° N. lat. This Alternative was not evaluated as part of the ROA analysis ([F.7, Attachment 1, March 2023](#)) for this cryptic species pair but is analyzed below by comparing it to Alternative 1, 2, Alternative 3, and Alternative 3a.

The SSC recommended three separate areas should be assumed for status determination: the Southern and Northern California assessments should be considered separate from Oregon and Washington because of the presence of sunset rockfish primarily south of Point Conception, and the Oregon and Washington assessments should be combined into a single stock area because of the lack of population structure within vermilion rockfish at the northern extent of its range ([Agenda Item E.3.a, Supplemental SSC Report 1, November 2021](#)). Vermilion and vermilion/sunset rockfish have consistently been delineated at a less than coastwide scale (Table 10).

Table 10. Comparison of annual catch limit (ACL) scale of species, NMFS status area, scientific and statistical committee (SSC) recommendation for) for population structure, and the most recent assessment for vermilion/sunset rockfish. North =N and South = S

Species (and Alts.)	ACL Scale	NMFS Status area(s)	SSC Pop. structure recommendation	Species Assessed	Assessment Area & Year
Vermilion and Vermilion /Sunset Rockfishes (1, 2, 2a, 3, 3a, 4)	Shelf Rockfish Complex North of 40° 10' N. lat.	a/	Washington and Oregon	Vermilion Rockfish	Washington (2021)
					Oregon (2021)
	Shelf Rockfish Complex South of 40° 10' N. lat.		California N. of 34° 27' N. lat.	Vermilion/Sunset Rockfish	California N. of 34° 27' N. lat. (2021)
			California S. of 34° 27' N. lat.		California S. of 34° 27' N. lat. (2021)

a/ Overfished or overfishing status was “unknown”, as of [June 2022 \(NMFS 2022\)](#).

Biological – Current BSIA, literature, and assessments do not consider vermilion/sunset rockfish a single stock but a set of cryptic species. These species in combination and individually, have distinct population structure at a finer geographic scale than coastwide (Appendix A: Biological Information). Vermilion rockfish was assessed as a single species off of Washington and Oregon (Cope et al, 2021, Cope and Whitman 2021 respectively) and the cryptic species pair vermilion/sunset rockfish were assessed off of California north of 34° 27' N. lat (Monk et al, 2021) and southern California (Dick et al, 2021). Vermilion rockfish are found along the entire coast; whereas, sunset rockfish is predominantly found south of 34° 27' N. lat., though is not uncommon in Central California. Alternatives 2-4 align to these findings. Alternative 3a is most aligned with BSIA and was recommended by the SSC ([Agenda Item E.3.a, Supplemental SSC Report 1, November 2021](#)). As noted above for other species, combining assessments can mask areas of localized depletion; whereas, sub-area assessments are more likely to reveal localized depletion. Alternative 1 has a higher risk of a coastwide status masking localized depletion compared to Alternatives 2-4. The vermilion and vermilion/sunset rockfish sub-area assessments (Alternative 4) are representative of localized dynamics and fishing effort for this species. Status determination at the same or similar scale as the assessments are more likely to be representative of region-based or local status than Alternative 1.

Socioeconomic - Compared to Alternatives 2-4, Alternative 1 is most likely to increase socioeconomic risks by requiring additional allocative decisions compared to status quo management. Socioeconomic impacts on fishing communities could change based on the outcome if any formal or informal allocation/apportionment becomes necessary. Alternatives 3 and 4 may be the least likely to change, through a subsequent action, socioeconomic impacts on coastal communities due to allocation policy changes compared to the 2023-24 biennial cycle. Both Alternatives 2, 2a, and 3a could make an allocation/apportionment necessary between Oregon and Washington in a future action but perhaps it would not differ substantially compared to the 2023-24 biennial cycle. Under Alternative 3a and 4, northern and southern California would be separate stocks with harvest specifications informed by an assessment and stock-specific HCRs; therefore, state-specific state allocations/apportionments may not be necessary.

Management - Alternative 2 is most similar to the current geographic scale of 2023 vermilion and vermilion/sunset rockfish harvest specifications, followed closely by Alternative 2a. State-specific stocks (Alternative 3) is most similar to the current geographic scale of management measures, including but not limited to harvest guidelines. It is assumed that both Alternative 2, 2a, 3 and 3a would likely be risk-neutral with regards to management burden of making allocative decisions. Like black rockfish, Alternative 1 might have a higher management burden than Alternatives 2, 2a, 3, and 3a because the species is not managed as a single unit at present. Alternative 4 could increase management burden by creating additional sub-divisions compared to status quo management. Dividing vermilion/sunset rockfish into four stocks (Alternative 4) may be at a smaller scale than biologically necessary, given the SSC has recommended a three-stock approach (Alternative 3a) ([Agenda Item E.3.a, Supplemental SSC Report 1, November 2021](#)).

Other considerations - Figure 2 and Figure 3 illustrate potential pathways to accomplish the harvest specifications calculations, consistent with the current harvest specifications framework in the FMP, for Alternative 2a and Alternative 3 or 3a, respectively. Each sub-area assessment would estimate an OFL contribution. Then a singular P^* and the SSC-recommended sigma would be applied for each sub-area assessment. Then the ABCs for two areas would be summed (i.e., N. California and S. California for Alternative 3, Washington + Oregon for Alternative 3a) to get three ABCs. A single ACL control rule would be applied to each stock's ABC to calculate each stock's ACL. Lastly, vermilion/sunset rockfish stock's OFLs/ABCs/ACLs would all be summed and then apportioned N. and S. of $40^{\circ} 10' N.$ lat. to calculate their respective contributions to the complexes in which they are managed (N./S. Shelf Rockfish Complexes). Additionally, to determine overfished status of vermilion/sunset rockfish as stocks north and south of $40^{\circ} 10' N.$ lat. as described under Alternative 2, a new assessment would be necessary. Alternatives 1, 2a, 3 and 3a presume that combining results of two or more Category 1 or 2 sub-area assessments would result in a stock assessment robust enough to determine overfished status of the stocks (i.e., Category of the assessment for the stock remains Category 1 or 2). Alternative 2a for vermilion rockfish would combine a Category 2 sub-area assessment (Washington, 2021) with a Category 1 sub-area assessment (Oregon, 2021).

Summary – Vermilion and vermilion/sunset rockfishes have been consistently delineated at less than coastwide across all evaluated metrics (Table 10). Sub-alternative 1a may result in similar ACL calculations as Alternatives 2, 3, 3a, and 4, however Alternative 1 is more likely to have increased socioeconomic risks and management burden compared to Alternatives 2-4. Alternative 3 is most likely to have a neutral socioeconomic or management burden risk of making inequitable allocations among the states. Additionally, under all alternatives, monitoring efficacy may be affected. However, until the Council adopts a formal definition, challenges for management and/or monitoring are highly uncertain.

PPA – The Council did not select a PPA in March 2023 for vermilion rockfish or the vermilion/sunset rockfish cryptic species pair.

3.4 Summary Table

Table 11 is a replica of Table ES 3 for reference. This table summarizes the aspects/factors identified in the above species specific tables.

Table 11. Table showing the combined information by species for this action. The left side shows the species, the alternatives it is considered under, and the resulting geographic delineation of the alternative. The right side summarizes the scientific and statistical committee (SSC) recommendation for population structure geographical delineation(s), NMFS Status Area, geographic scale at which the ACL is currently set, and the most recent assessment geographic delineation(s) and year. Preliminary Preferred Alternative (PPA) is noted in bold as is alternatives added to the Range of Alternatives

Alternative Specifics by Species			Pop. Structure, Status, ACL scale, and Assessment Delineations Information			
Species	Alternative	Delineation	SSC population structure recommendation	NMFS Status Area	ACL Scale	Assessment Stratification and Year a/
Canary Rockfish	1 (PPA)	Single Stock	Coastwide	Pacific Coast	Coastwide	Coastwide (2015)
Dover Sole	1 (PPA)	Single Stock	Coastwide	Pacific Coast	Coastwide	Coastwide (2021)
Pacific Spiny Dogfish	1 (PPA)	Single Stock	Coastwide	Pacific Coast	Coastwide	Coastwide (2021)
Petrale Sole	1 (PPA)	Single Stock	Coastwide	Pacific Coast	Coastwide	Coastwide (2021)
Rex Sole	1 (PPA)	Single Stock	Coastwide	Pacific Coast	Coastwide	Coastwide (2013)
Shortspine Thornyhead b/	1 (PPA)	Single Stock	Coastwide	Pacific Coast	Coastwide	Coastwide (2013)
Sablefish c/	1 (PPA)	Single Stock	Coastwide	Pacific Coast	Coastwide	Coastwide (2019)
Lingcod	2 (PPA)	North of 40° 10' N. lat.	North of 40° 10' N. Lat.	North Pacific Coast	North of 40° 10' N. lat.	North of 40° 10' N. lat. (2021)
		South of 40° 10' N. lat.	South of 40° 10' N. lat.	South Pacific Coast	South of 40° 10' N. lat.	South of 40° 10' N. lat. (2021)
Black Rockfish d/	1	Single Stock	Washington	Washington	Washington	Washington (2015)
	3 (PPA)	WA	Oregon	Oregon	Oregon	Oregon (2015)
		OR	California	California	California	California (2015)
		CA				
Copper Rockfish	1	Single Stock	North of 42°N. lat. and South of 42° N. lat.	Pacific Coast e/	Nearshore Rockfish Complex North of 40° 10' N. lat.	Washington (2021) Oregon (2021) California –N of 34° 27' N. lat. (2021)
	2a (PPA)	North of 42° N. lat.				
		South of 42° N. lat.				
	3	WA			Nearshore Rockfish Complex South of 40° 10' N. lat.	California S of 34° 27' N. lat. (2021)
		OR				
		CA				

Alternative Specifics by Species			Pop. Structure, Status, ACL scale, and Assessment Delineations Information			
Species	Alternative	Delineation	SSC population structure recommendation	NMFS Status Area	ACL Scale	Assessment Stratification and Year a/
Quillback Rockfish	1	Single Stock	Washington Oregon California	f/	Nearshore Rockfish Complex North of 40° 10' N. lat.	Washington (2021) Oregon (2021) California (2021)
	2a (NEW)	North of 42° N. (a Washington and Oregon stock)				
		South of 42°N .lat. (a California stock)				
	3(PPA)	WA				
		OR				
		CA				
Squarespot Rockfish	1 (PPA)	Single Stock	California	f/	Shelf Rockfish Complex North of 40° 10' N. lat.	California (2021)
	3	WA			g/	
		OR				
		CA				
Vermilion and Vermilion/ Sunset Rockfishes	1	Single Stock	Washington and Oregon h/ California [north of 34° 27' N. lat.] (2021) California [south of 34° 27' N. lat.] (2021)	f/	Shelf Rockfish Complex North of 40° 10' N. lat.	Washington (2021) Oregon (2021) California [north of 34° 27' N. lat.] (2021)
	2	North of 40° 10' N. lat.				
		South of 40° 10' N. lat.				
	2a (NEW)	North of 42° N. (a Washington and Oregon stock)				
		South of 42°N .lat. (a California stock)				
	3	WA			Shelf Rockfish Complex South of 40° 10' N. lat.	
		OR				
		CA				

Alternative Specifics by Species			Pop. Structure, Status, ACL scale, and Assessment Delineations Information			
Species	Alternative	Delineation	SSC population structure recommendation	NMFS Status Area	ACL Scale	Assessment Stratification and Year a/
Vermilion and Vermilion/ Sunset Rockfishes	3a	WA & OR				
		N. CA				
		S. CA				
	4	WA				
		OR				
		N. CA				
		S. CA				

a/ Most recent sub-areas for assessments endorsed as BSIA by the SSC and NMFS. Assessment area stratifications may change in future assessments.

b/ Shortspine thornyhead has an ACL that is apportioned north and south of 34° 27' N. lat., consistent with allocations in the FMP.

c/ Sablefish has an ACL that is apportioned north and south of 36° N. lat., consistent with allocations in the FMP.

d/ Black rockfish off Washington and California each have both overfished and overfishing status determinations. Oregon Black rockfish is managed in a complex and only has overfished status determinations. Overfishing status determinations are made for the Oregon black/blue/deacon Rockfish Complex.

e/ Note: NMFS made a “not overfished” status determination for “copper rockfish - Pacific Coast” based on the 2013 assessment, though catches since that time have doubled. The 2013 assessment also assumed a more optimistic status in 2000 than was found in the 2021 stock assessment.

f/ Species have overfished or overfishing status as “unknown”, as of [June 2022 \(NMFS 2022\)](#).

g/ Squarespot rockfish contributes 0 mt to the Shelf Rockfish North complex (2023-24).

h/ The SSC recommended combining vermilion rockfish in Oregon and Washington for status determination due to lack of population structure between the two areas – [Agenda Item E.3.a, Supplemental SSC Report 1, November 2021](#)

4. Considerations Relating to Council Operating Procedures (COPs)

This section collects considerations that are somewhat ancillary to other chapters of this document.

4.1 New Information and Timing Considerations

New scientific information indicating species' stock definition(s) may need to be reconsidered by the Council could become available at any time during ongoing fishery management. However, to ensure a consistent and transparent process, the team presents two proposals for Council consideration regarding integration of new stock definition science into the biennial process. A diagram () illustrates the two proposals side-by-side for ease of comparison, and are described in greater detail below.

The project team recommends that the process for considering new scientific information regarding stock definitions, and pathways for considering changes to stock definitions, be described in [Council Operating Procedure 9 \(COP 9\)](#): Biennial Management Cycle and Activities related to Groundfish Management. This process would first be initiated for those species to be assessed in 2025 for the next biennial cycle (i.e., 2027-2028). It is important to note, Phase 2 of the Stock definition process will address the remaining species in the FMP, and may also overlap with the development of the 2027-2028 harvest specifications and management measures.

The Council could adjust these proposed schedules in the future, as needed, by revising COP 9. Both NMFS and the Council should give additional thought to timing considerations.

Proposal 1

In March of even years, the Northwest Fishery Science Center (NWFSC) provides the initial list of stocks that are prioritized for assessments to the Council. At that meeting, the Council may adopt the recommendations and/or modify it as their PPA. The Council adopts their FPA for the list of species/stocks to be assessed at their June (even year) meeting. Over the course of the summer, the prioritized list of stocks will be investigated for population structure information by the appropriate, advisory body, or Council staff.²⁴ At the September Council meeting (even years), the Council would scope an amendment to the FMP to revise stock definitions if new information was available that would compel revisions to a stock(s) definition and the Council could adopt an ROA for public review. If no new information was available, this process would cease at this point. At the March Council meeting (odd years), the Council would adopt their PPA for new/revised stock definitions. At the June Council meeting (odd years), the Council would adopt their FPA stock definitions. This proposal is similar to how this process was completed this year.

Proposal 2

In March of even years, the Northwest Fishery Science Center (NWFSC) provides the initial list of stocks that are prioritized for assessments to the Council. At that meeting, the Council would

²⁴ new information to the Council related to stock definitions are Council members, NMFS scientists, etc.; however, this list is non-exhaustive. A key consideration for new information is it should be in the form of peer reviewed literature or other reviewed literature (e.g., 'gray literature', technical reports, etc.) that have verifiable citations and are publicly available. New information brought through pre-assessment workshops will also be considered, if timing allows.

adopt both the PPA for stocks to be assessed and instruct staff to investigate those stocks for information that may dictate a change in the stock definition. At the June meeting (even years), the Council would scope an amendment to the FMP to revise stock definitions if new information was available that would compel revisions to a stock(s) definition and the Council could adopt an ROA for public review. If no new information was available, this process would cease at this point. At the September (even years), the Council would adopt their FPA new stock definitions.

Comparison of Proposals

Proposal 1 occurs concurrently with the pre-assessment and assessment processes. The Council would adopt new stock definitions at their June (odd years) meeting. This meeting is generally before the first Stock Assessment Review (STAR) panel; however, in some years the STAR panel could meet before the Council took final action on any new stock definition, publishing results of stock assessments before final preferred stock definitions are adopted by the Council. This schedule suggests there could be more direct involvement of Council staff and, potentially, the GMT. However, the downside to Proposal 1 is it limits any involvement of stock assessors as they would be heavily involved with the assessment process and have very limited availability. Additionally, Proposal 1 would not re-define/define the stock until the assessment is well underway.

Proposal 2 occurs concurrently with the stock assessment prioritization phase and the last three Council meetings of the biennial harvest specifications and management measures process. The Council would adopt final preferred new stock definitions in September (even years) and prior to most pre-assessment work. Proposal 2 would limit Council staff and GMT involvement as it would overlap the management measures phase of the biennial harvest specifications and management measures process. However, it could, potentially, allow more involvement from assessors. A benefit to this Proposal is assessors would begin and complete assessments with a revised Council-recommended stock definition.

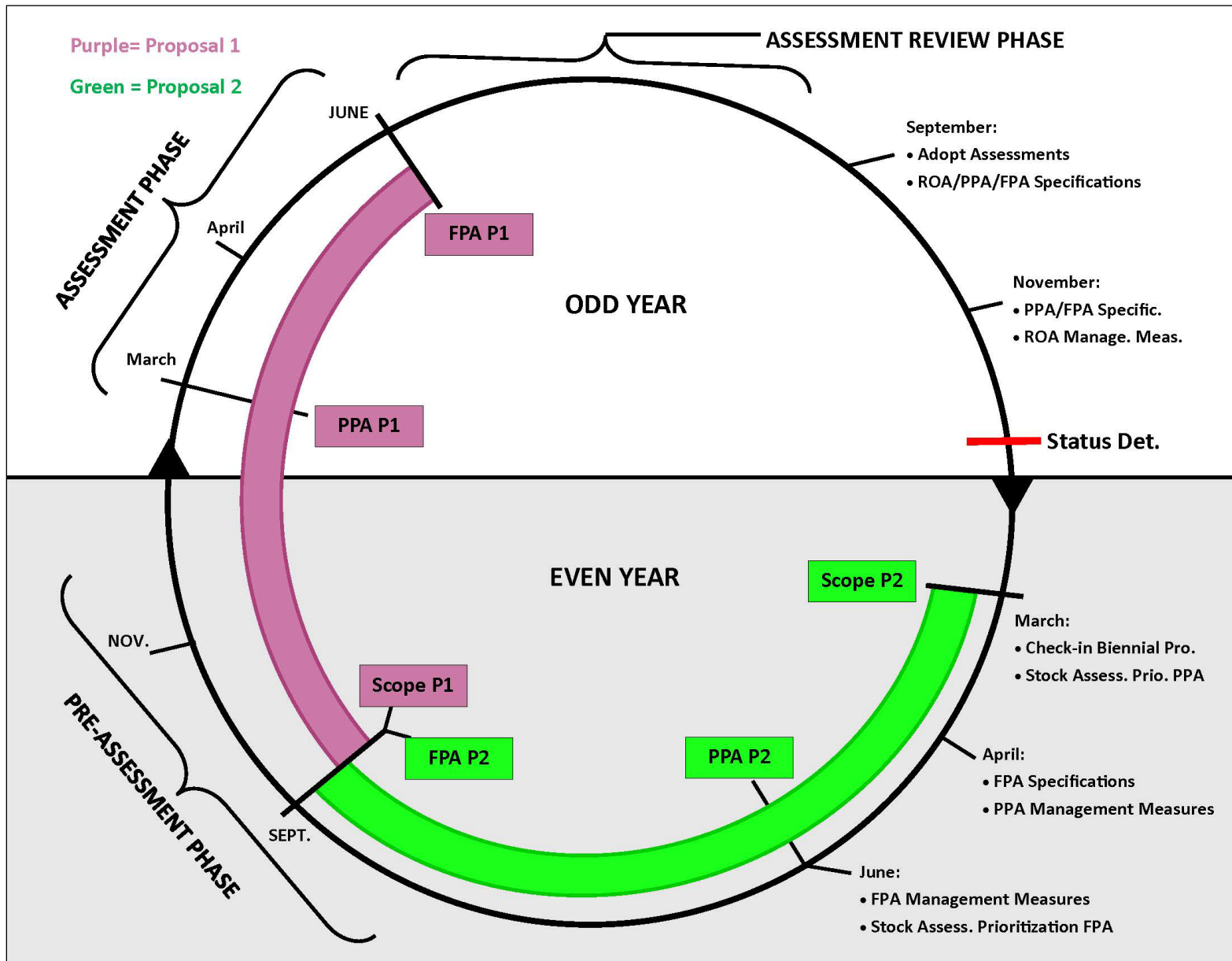

Figure 4. Biennial groundfish management cycle diagram showing two proposals (Proposal 1 in purple and Proposal 2 in green) for potential on-ramps for new scientific information to inform stock definitions

Page left blank intentionally

5. Magnuson-Stevens Act National Standards

The project team offers the following considerations related to the NS guidelines for consideration during selection of the final preferred alternatives. Unless otherwise stated, “this action” refers to the Council’s PPA.

5.1 National Standard 1 - Optimum Yield

All action alternatives would improve the FMP’s alignment with NS1 compared to the No Action alternative because there would be sufficient information for NMFS to make status determinations for each of the priority species²⁵. Status determination is needed to understand if conservation and management measures achieve OY. The alternatives should allow for the Council to adopt harvest specifications and management measures (in a separate, future action) that achieve optimum yield (OY) from a stock, and in turn, the fishery. Subsequent actions will build on this process until all managed groundfish species are defined as stocks.

The FMP ([§4.5](#)) describes the use of minimum stock size threshold (MSST) and the maximum fishing mortality threshold (MFMT) in status determination. Assessments calculate MSST, MFMT, and MSY for the assessed species and areas, which may be used to inform overfished status determinations. The Council has adopted OFLs and related harvest specifications, including accountability measures, for all managed species and has sector specific management measures designed to achieve, but not exceed harvest specification reference points (PFMC 2022a, PFMC, 2022b). These reference points are not species specific (e.g., for rockfish, flatfish, elasmobranchs, etc.) and have generally been used to determine the status of the species, but they will be used to determine the overfished status of the stocks, as defined in the FMP by this action, or by comparing catch to OFLs to determine whether overfishing is occurring.

It is unlikely that we will ever have enough information to remove all doubt that a stocks’ definition aligns with the biogeography of a species. However, we may be able to measure whether a stocks’ definition is making an appreciable difference in our ability to achieve OY from a stock. When a coastwide-ranging stock has multiple assessment areas, and one area appears to have much higher depletion, or an abundance trajectory that is much different from other assessed areas, this may be an indicator that, for the portion of the population with higher depletion, we are failing to achieve OY.

If status determinations, which are a key trigger to hold Councils accountable for meeting the requirements under NS1, are made at a scale that is mis-aligned with population structure of a species within the FMU, then the stock definition is more likely to fail to achieve OY. It is acknowledged that management measures taken at a finer scale may substantially mitigate risks of failing to achieve OY; however, according to the NS1 guidelines, it is not an adequate substitute for stock definitions that yield status determinations designed to achieve OY.

²⁵ Assuming the presence of a Category 3 sub-area assessment does not discount results of Category 1 or 2 sub-area assessments for the assessed stock that have been deemed BSIA.

The alternatives would each result in different geographic scale of overfished status determinations. It is currently unclear whether the stock's assessment Category could or should change when sub-area assessments are combined to equal the geographic scale of the stock (whether the same Category or different Categories). Since the Category of the stock's assessment must be a Category 1 or 2 to be used for overfished stock status determinations, per the FMP, it is relevant to consider this question during this proposed action. The answer to this question could affect NMFS' ability to make overfished status determinations for stocks that have more than one contributing sub-area assessment.

The alternatives would each result in OFL calculations at different geographic scales, depending on how stocks are defined. However, none of the alternatives would change NMFS' ability to make overfishing status determinations, because it does not change how/when OFLs are calculated and implemented in regulations, nor would the alternatives change the species compositions of any stock complexes. None of the action alternatives would change NMFS' ability to make overfishing status determinations for stocks or stocks managed in stock complexes.

5.2 National Standard 2 - Best Scientific Information Available

Stock definitions are a Council decision, and Councils have discretion to make a policy decision on how to define stocks. That said, conservation and management measures (including stock definitions and SDC) must be based on the best scientific information available (BSIA). If BSIA indicates population structure at a finer scale than would be expected in a single stock, the Council should strongly consider this information, in light of other fishery management objectives. When considering combining sub-area assessments, the Council should seek input from the SSC. Rationale for combining sub-area assessments for stock definitions (and also, therefore, status determinations), especially if not SSC-recommended, would need to be outlined by the Council. NMFS would evaluate whether the rationale adequately demonstrate consistency of the Council's decision with BSIA.

BSIA is informed by, but not limited to, stock assessments, research, published scientific literature, and technical reports. Appendix A: Biological Information consolidates and synthesizes available information for the priority species. Stock assessments incorporate established information as well as consider new and emerging concepts. The SSC and the Council are informed at multiple stages by NMFS NWFSC and SWFSC leadership regarding stock assessment planning and how the assessment(s) will be structured.²⁶ The pre-assessment workshops aid in verifying and validating all sources of data that can be used in the assessment. Ultimate determination of BSIA for federal fisheries management lies with the Secretary of Commerce, as informed by advice from NMFS as described in the [West Coast BSIA Regional Framework documentation](#).

Assessments are open to the public and are peer reviewed through the Council's Stock Assessment Review (STAR) process or by the SSC itself. The SSC is tasked by the Council to review the findings of the assessment and STAR Panel. The SSC independently assesses that process and provides recommendations to the Council regarding whether the stock assessment is sufficient to provide management advice. The SSC will also recommend if the assessment is BSIA and what

²⁶ refer to [Council Operating Procedure 9](#) and the [Terms of Reference for the Groundfish Stock Assessment Review process of 2023-2024](#).

Category the assessment is (i.e., if it is robust enough for informing overfished status determinations). The SSC may also make recommendations for Council consideration regarding the geographic scale of the stock.

Each of the priority species was assessed in 2021 or will be assessed in 2023. Each of these species have been assessed previously and the SSC has endorsed the assessments, as well as recommended for Council consideration the scale for status determination of each species. The above analysis states the BSIA findings from each assessment (and SSC recommendations, when available). Regarding the priority species, the population structure of certain species, notably nearshore rockfish, may not support a single stock (coastwide) definition under Alternative 1.

Nearshore rockfish, like all rockfish, release pelagic larvae; however, larval dispersal may be limited for a number of reasons, such as biological features of the larvae, high site fidelity by adults, oceanographic eddy interference, and large-scale oceanographic barriers limiting distribution of genetic diversity, etc. In brief, these natural oceanographic and life history characteristics could result in limited mixing and could result in isolating some populations from others. These factors indicate status determinations should be considered at a smaller scale than coastwide for multiple nearshore species. A single stock definition for some nearshore stocks could, therefore, be in conflict with the National Standard 2 guidelines.

The following bullet point summarizes the SSC BSIA recommendations regarding priority species stock status area delineations.

- *Single stock, single population:* Canary rockfish, Dover sole, Pacific spiny dogfish, petrale sole, rex sole, sablefish, shortspine thornyhead, squarespot rockfish
- *Multiple stocks, multiple area populations:* Lingcod, black rockfish, copper rockfish, quillback rockfish, vermilion rockfish and the vermilion/sunset rockfish cryptic species pair.

5.3 National Standard 3: Management Units

NS 3 guidance is, in brief, that an individual stock shall be managed as a unit throughout its range and interrelated stocks will also be managed as a unit. The PFMC manages groundfish species specified in the FMP in Federal waters off of California, Oregon, and Washington. If a species range is greater than the Council's jurisdictional geographic scale, those areas are not considered within the scope of this action or the Council's management authority. At present, the impacts of this action related to NS 3 are unknown; however, all the stocks proposed to be defined are managed "in the fishery" under the same FMP .

5.4 National Standard 4: Allocations

It is presumed that, subsequent to this action, the harvest specifications for each stock will continue to be based on the harvest specifications framework in the FMP and will be based on BSIA. Under Alternative 3, state-specific stocks may have harvest specifications informed by a state-specific stock assessment. Also under Alternative 3, state-specific stocks may have harvest specifications informed by multiple sub-area assessments. In both of these cases, the amount of harvestable surplus available off the coast of each state would be established based on BSIA, and not decided by an allocation. Under Alternatives 1, 2, 2a and 3a, a stock may span multiple states. In such cases, an allocative decision to apportion harvestable surplus among states may be necessary in a

future action. Allocative decisions must be made consistent with NS4, the allocation framework in the FMP, and other applicable laws and policies. This action does not directly allocate harvestable surplus among states, however, for black and quillback rockfishes, the PPA stock definition partitions stocks between states as an approximation of best estimates of each species' population biomass. Such action is not intended to be allocative in nature, and harvestable surplus off the coast of each state would be based on BSIA. Therefore, this action will not discriminate between residents of different states.

5.5 National Standard 5: Efficiency

Conservation and management measures shall, where practicable, consider efficiency in the utilization of fishery resources; except that no such measure shall have economic allocation as its sole purpose.

This action would define stocks based on BSIA. BSIA, notably stock assessments, take into account the biology of and the fishery activity on a species or stock. BSIA is expected to inform opportunities to harvest the OY of the stock in a manner that reflects the historical and recent fishing activity of a given region. Adoption of Alternatives that more closely align with current management would be expected to maintain the state of the fishery at present, preserving existing efficiencies. Adopting alternatives that are expected to result in different management measures could alter efficiencies in current harvest strategies. This, in turn, could impact the ability of the fishery to achieve OY.

5.6 National Standard 6: Variations and Contingencies

Conservation and management measures shall take into account and allow for variations among, and contingencies in, fisheries, fishery resources, and catches.

This action is necessary to provide enough information on stock boundaries in the FMP to inform NMFS' status determinations. This action is expected to reflect the current scientific knowledge while allowing for variations and contingencies in our scientific understanding of the resources as they relate to the reference points in the FMP. Specificity in geographic or latitudinal boundaries (e.g., North and south of 40° 10' N. lat.) can and should be used to set harvest specifications and describe management measures in regulations that have on-the-water effects, affecting things like fishing activity, fishery monitoring, and enforcement of fishing prohibitions.

5.7 National Standard 7: Costs and Benefits

This action is administrative in nature and will not modify any management measures that would change costs, duplicity in regulations, or change the burden placed on user groups. Costs and benefits will be evaluated when the 2025-2026 harvest specifications and management measures are developed based on the new stock definitions. As discussed in Section 3.3- Species Specific Comparison of Alternatives, a stock definition alternative that is likely to require future allocative action of the resource between the states could have an increased risk of those allocations being less fair and equitable than comparable sharing agreements established in the 2023-24 harvest specifications and management measures.

5.8 National Standard 8: Communities

This action does not make changes to any conservation and management measures that impact communities, however alternatives that define stocks at a smaller geographic scale are expected to result in future management measures that will have a more localized effect on communities. Defining stocks is largely administrative action and does not directly or indirectly cause socioeconomic impacts to port communities, i.e., impacts of this action could be considered neutral. This action defines stocks for which overfished or not overfished status may be determined by NMFS. If a stock is determined to be overfished, the Council will be obligated to design a rebuilding plan that rebuilds the stock as quickly as possible taking into account the needs of fishing communities (among other factors). In that situation, the impacts of harvest specifications and management measures on fishing communities will be explicitly discussed in a future action. Regardless of overfished status, when these definitions are applied in a future action, i.e., through the harvest specifications, the impacts to communities will be analyzed relative to status quo.

5.9 National Standard 9: Bycatch

This action does not make changes to any conservation and management measures that influence or minimize bycatch.

5.10 National Standard 10: Safety of Life at Sea

This action is not expected to change any aspect of conservation and management measures that could compromise the safety of human life at sea.

5.11 Consistency of the Proposed Action with Other Applicable MSA Provisions

5.11.1 MSA Section 303

Section 303(a)(9) of the Magnuson-Stevens Act requires that a fishery impact statement be prepared for each FMP or FMP amendment. A fishery impact statement is required to assess, specify, and analyze the likely effects, if any, including the cumulative conservation, economic, and social impacts, of the conservation and management measures on, and possible mitigation measures for (a) participants in the fisheries and fishing communities affected by the plan amendment; (b) participants in the fisheries conducted in adjacent areas under the authority of another Council; and (c) the safety of human life at sea, including whether and to what extent such measures may affect the safety of participants in the fishery. A Categorical Exclusion was prepared for this plan amendment. The likely effects of this action are limited to administrative changes to the plan amendment and do not constitute impacts to the fishery. Impacts to the fishery, including Amendment 31 stock definitions, will be evaluated as part of the 2025-2026 harvest specifications and management measure process. Therefore, the effects on participants in the fisheries and fishing communities are not analyzed in this document. The effects of the action on safety of human life at sea are evaluated above in Section 5.10, National Standard 10.

The PPA does not include new conservation and management measures and therefore is not expected to affect fisheries and fishing communities, fisheries in adjacent areas, or the safety of human life at sea because it is largely administrative in nature.

5.11.2 MSA Section 600.305

While discussed in detail above, it is important to note how the Council came to its PPA stock definitions.

§600.305(c)(1) includes a non-exhaustive list of ten things that a Council should consider when deciding stocks that require conservation and management and §600.305(c)(3) notes that additional considerations may be relevant to particular stocks. This list is evidence that scientific information alone need not be the only indicator the Councils use to define stocks in need of conservation and management, and that National Standards can still be met with imperfect or incomplete scientific information. The interaction between NS1 and NS2 is considered at §600.305(e)(1), which describes using proxies and making added effort to identify and gather available information.

Recognizing the need to make stock definition recommendations with incomplete or imperfect scientific information to inform these decisions, a thorough literature review was conducted, to synthesize the best available scientific information regarding population structure for the priority species (Appendix A: Biological Information). This allowed the Council, paired with the advice of its SSC, to make recommendations for stock definitions for the priority species that were based on BSIA, consistent with NS2.

The Council recognized the importance of NS1, NS2 and NS3 considerations when shaping the purpose and need and range of alternatives for this action. As the analysis developed, it became clearer how these three National Standards intersected, in the context of the purpose and need and the current frameworks in the FMP. For example, it became clear that reference points in the FMP pertained to the stock, as defined through this action²⁷. Additionally, it became clear that default ACL control rules in the FMP would also pertain to the stock, as defined through this action.

²⁷ This interpretation is consistent with §600.305(e)(2), which contemplates the relationship of NS3 to NS1, and §600.310(e)(1)(ii), which defines MSY for stocks.

6. Glossary

Acceptable Biological Catch (ABC): A harvest specification that accounts for the scientific uncertainty in the estimate of OFL, and any other scientific uncertainty.

Annual Catch Limit (ACL): A harvest specification set equal to or below the ABC in consideration of conservation objectives, socioeconomic concerns, management uncertainty, ecological concerns, and other factors. The ACL is a harvest limit that includes all sources of fishing-related mortality including landings, discard mortality, research catches, and catches in exempted fishing permit activities. Sector-specific ACLs can be specified, especially in cases where a sector has a formal, long-term allocation of the harvestable surplus of a stock or stock complex. The ACL serves as the basis for invoking AMs.

Assessment Unit: The area at which the assessment is conducted/modeled. Assessors often refer to this as **the “stock,”** which is not equivalent to the “stock” under MSA. The stock may be assessed across areas that only comprise segments of the coast or coastwide depending upon the species biology, data availability, exploitation history, etc.

Fishery Management Unit (FMU): For the purposes of this document, this term is a geopolitical unit that is equivalent to the cumulative geographic area that is within the jurisdiction of the Fishery Management Plan. For the Pacific Coast Groundfish Fishery Management Plan, FMU refers to the EEZ off the coasts of Washington, Oregon, and California. This may or may not include the entire range or distribution of a single species.

Localized depletion: Localized depletion is a way of characterizing when a portion of a stock, or within a part of a species’ range, has estimated abundance that lower than for other portions of the stock or areas of the species’ range. Localized depletion may be caused by a number of factors, including but not limited to, fishing pressure, local habitat loss or degradation, ecological changes, environmental conditions, etc. Localized depletion may be mitigated in a number of ways, including but not limited to, spillover of fish from areas of higher abundance, local reductions in fishing pressure, etc.

Harvest Control Rule (HCR): In the FMP, HCRs are generally qualified by another term such as the MSY control rule, ABC control rule, etc. See full description in call-out-box in Appendix A: Biological Information.

Metapopulation: A system of interacting biological populations that exhibit a degree of independence in local population dynamics as well as connectivity between populations ([Cadrin et al. 2014](#); Levins, 1969)

Overfishing limit (OFL): The MSY harvest level or the annual abundance of exploitable biomass of a stock or stock complex multiplied by the maximum fishing mortality threshold or proxy thereof and is an estimate of the catch level above which overfishing is occurring ([FMP](#))

Population: A group of interbreeding individuals that exist together in time and space that are isolated from other groups ([Waples and Gaggiotti, 2006](#); Taylor and Taylor, 1977; Mayr, 1942).

Sub-population: A delineated subset of individuals within a population ([Wells and Richmond 1995](#))

Species: A group of living organisms consisting of similar individuals capable of exchanging genes or interbreeding ([Milius, 2017](#); [Mayr, 2000](#)). Refers to the genus and species; the unit as it is included in the FMP off the U.S. West Coast.

Status: Status is a determination of the health of a stock of fish and is reported to Congress quarterly by NMFS. A stock may be determined by NMFS to have any of the following overfished statuses: “unknown”, “overfished”, “not overfished”, or “approaching an overfished” condition. A stock may be determined by NMFS to have any of the following overfishing statuses: “unknown”, “subject to overfishing”, or “not subject to overfishing”.

Status Determination Criteria (SDC): SDC mean the measurable and objective factors, maximum fishing mortality threshold (MFMT), OFL, and minimum stock size threshold (MSST), or their proxies, which are used to determine if overfishing has occurred, or if the stock or stock complex is overfished. SDC are required to be identified in every FMP. See full description at [50 CFR 600.310\(e\)\(2\)](#).

Sub-area assessment: term to describe an assessment unit when multiple assessment areas are used to assess a single species or a stock (e.g., a single stock may have sub-area assessments for different areas or portions of the stock based on data availability). Sub-area assessment results may be combined to estimate abundance and OFL, for overfished and overfishing status determinations, respectively.

Sub-species: Aggregate of phenotypically similar populations of a species inhabiting a geographic subdivision of the range of that species and differing taxonomically from other populations of that species ([Mayr, 2000](#); Mayr and Ashlock, 1991)

Status determination: The Secretary of Commerce makes formal determinations and the Status of Stocks are reported to Congress quarterly. Status determinations include, but are not limited to, “overfished” (relates to biomass of a stock or stock complex), and “overfishing” (pertains to a rate or level of removal of fish from a stock or stock complex).

Stock: The term "stock of fish" means a species, subspecies, geographical grouping, or other category of fish capable of management as a unit. (16 U.S.C. 1802 MSA §3(42)). It is a delineation of a species (or group of species) that is made at the discretion of the Council (e.g., a policy decision), based on BSIA and other relevant management needs; stocks are required to be defined in the FMP (i.e., subject to deliberative public process and Secretarial approval), per NS1 guidelines. This is the unit at which status determinations are made and OFLs should be set.

7. Literature Cited

- Abookire, A. A. 2006. Reproductive biology, spawning season, and growth of female rex sole (*Glyptocephalus zachirus*) in the Gulf of Alaska. *Fish Bull.* 104:350-359.
- Abookire, A. A. and Bailey, K.M. 2007. The distribution of two deep-water pleuronectids, Dover sole (*Microstomus pacificus*) and rex sole (*Glyptocephalus zachirus*), at the northern extent of their range in the Gulf of Alaska. *J. of Sea Research* 57:198-208.
- Alderdice, D. F. and Forrester, C. R. 1971. Effects of salinity and temperature on embryonic development of the petrale sole (*Eopsetta jordani*). *J. Fish. Res. Board Canada* 28:727-744.
- Alverson, D. L. and Chatwin, B. M. 1957. Results from tagging experiments on a spawning stock of petrale sole, *Eopsetta jordani* (Lockington). *J. Fish. Res. Board Canada* 14:953-974.
- Andrews, K. S., K. M. Nichols, A. Elz, N. Tolimieri, C. J. Harvey, R. Pacunski, and coauthors. 2018. Cooperative research sheds light on population structure and listing status of threatened and endangered rockfish species. *Conservation Genetics* 19: 865-878.
- Andrews, K. S., Bartos B., Harvey, C. J., Tonnes, D., Bhuthimethee, M., and P. MacCready. 2021. Testing the potential for larval dispersal to explain connectivity and population structure of threatened rockfish species in Puget Sound. *Marine Ecology Progress Series* 677: 95-113.
- Ayres, D.L. 1988. Black rockfish investigations. A summary of 1986 and 1987 black rockfish tagging studies. Washington Department of Fisheries. Progress Report No. 263.
- Baetscher, D.S., Anderson, E.C., Gilbert-Horvath, E.A., Malone, D.P., Saarman, E.T., Carr, M.H., and Garza, J.C. 2019. Dispersal of a nearshore marine fish connects marine reserves and adjacent fished areas along an open coast. *Molecular Ecology* 28, 1611–1623. <https://doi.org/10.1111/mec.15044>.
- Bailey, K. M., A. A. Abookire, and J. T. Duffy-Anderson. 2008. Ocean transport paths for the early life history stages of offshore-spawning flatfishes: a case study in the Gulf of Alaska. *Fish and Fisheries* 9: 44-66.
- Baker, B. M. 1999. Genetic analysis of eight black rockfish collections from northern Oregon. Washington Department of Fish and Wildlife, 27 p.
- Bassett, M., Lindholm, J., Garza, C., Kvitek, R., and Wilson-Vandenberg, D. 2018. Lingcod (*Ophiodon elongatus*) habitat associations in California: Implications for conservation and management. *Environmental Biology of Fishes* 101(1): 203–213.
- Berger, A.M., Harley, S.J., Pilling, G.M., Davies, N. and Hampton, J., 2012. Introduction to harvest control rules for WCPO Tuna fisheries mow1-ip/06 14 nov 2012. Cited on, p.3.

- Berger, A.M., Deroba, J.J., Bosley, K.M., Goethel, D.R., Langseth, B.J., Schueller, A.M. and Hanselman, D.H., 2021. Incoherent dimensionality in fisheries management: consequences of misaligned stock assessment and population boundaries. *ICES Journal of Marine Science*, 78(1), pp.155-171.
- Berntson, E.A., Moran, P., 2008. The utility and limitations of genetic data for stock identification and management of North Pacific rockfish (*Sebastes* spp.). *Rev Fish Biol Fisheries* 19, 233–247. <https://doi.org/10.1007/s11160-008-9101-2>.
- Bishop, M.A., Reynolds, B.F., and Powers, S.P., 2010. An in situ, individual-based approach to quantify connectivity of marine fish: ontogenetic movements and residency of lingcod. *Plos One*, 5(12), p.e14267.
- Boehlert, G.W. 1977. Timing of the surface-to-benthic migration in juvenile rockfish, *Sebastes diploproa*, off southern California. *U.S. Fish. Bull.* 75:887–890
- Boehlert, G. W. 1980. Size composition, age composition, and growth of canary rockfish, *Sebastes pinniger*, and splitnose rockfish, *S. diploproa*, from the 1977 rockfish survey. *Mar. Fish. Rev* 42:57–63.
- Boehlert, G. W. and Yoklavich, M.M., 1983. Effects of temperature, ration, and fish size on growth of juvenile black rockfish, *Sebastes melanops*. *Environmental Biology of Fishes*, 8, pp.1-28
- Boehlert, G. W., and M. M. Yoklavich. 1984. Variability in age estimates in *Sebastes* as a function of methodology, different readers, and different laboratories. *California Fish and Game* 70:210–224.
- Boehlert, G. W., and M. M. Yoklavich. 1985. Larval and juvenile growth of sablefish, *Anoplopoma fimbria*, as determined from otolith increments. *Fishery Bulletin*, 83(3), pp.475-481.
- Bosley, K.M., Goethel, D.R., Berger, A.M., Deroba, J.J., Fenske, K.H., Hanselman, D.H., Langseth, B.J. and Schueller, A.M., 2019. Overcoming challenges of harvest quota allocation in spatially structured populations. *Fisheries Research*, 220, p.105344. et al. 2019)
- Bosley, K.M., Schueller, A.M., Goethel, D.R., Hanselman, D.H., Fenske, K.H., Berger, A.M., Deroba, J.J. and Langseth, B.J., 2022. Finding the perfect mismatch: Evaluating misspecification of population structure within spatially explicit integrated population models. *Fish and Fisheries*, 23(2), pp.294-315.
- Brodeur, R. D., I.A. Fleming, J. M. Bennett, and M. A. Campbell. 2009. Summer distribution and feeding of spiny dogfish off the Washington and Oregon coasts. in V. F. Gallucci, G. A. McFarlane, and G. G. Bargmann, editors. *Biology and Management of Dogfish Sharks*. American Fisheries Society.

- Brooks, R.O. 2021. Geographic Variability in the Life History and Demography of Canary Rockfish, *Sebastes pinniger*, Along the U.S. West Coast. Capstone Projects and Master's Theses.
- Budrick, J. E. 2016. Evolutionary Processes contributing to Population Structure in the Rockfishes of the Subgenus *Rosicola*: Implications for Fishery Management, Stock Assessment and Prioritization of Future Analyses of Structure in the Genus *Sebastes*. PhD. University of California, Berkeley, Berkeley, California.
- Buonaccorsi, V.P., Kimbrell, C.A., Lynn, E.A., and Vetter, R.D. 2002. Population structure of copper rockfish (*Sebastes caurinus*) reflects postglacial colonization and contemporary patterns of larval dispersal. *Canadian Journal of Fisheries and Aquatic Sciences* 59, 1374–1384.
- Buonaccorsi, V.P., Westerman, M., Stannard, J., Kimbrell, C., Lynn, E., and Vetter, R.D. 2003. Molecular genetic structure suggests limited larval dispersal in grass rockfish, *Sebastes rastrelliger*. *Marine Biology* 1, 1–1.
- Buonaccorsi, V. P., C. A. Kimbrell, E. A. Lynn, and R. D. Vetter. 2005. Limited realized dispersal and introgressive hybridization influence genetic structure and conservation strategies for brown rockfish, *Sebastes auriculatus*. *Conservation Genetics* 6:697-713.
- Brodziak, J., and Mikus, R. 2000. Variation in life history parameters of Dover sole, *Microstomus pacificus*, off the coasts of Washington, Oregon, and northern California. *Fish Bulletin* 98: 661-673.
- Butler, J.L., Dahlin, K.A., and Moser, H.G. 1996. Growth and duration of the planktonic phase and a stage based population matrix of Dover sole, *Microstomus pacificus*. *Bull. Mar. Sci.* 58, 29–43.
- Cadrin, S.X., 2020. Defining spatial structure for fishery stock assessment. *Fisheries Research*, 221, p.105397.
- Cadrin, S.X. and Secor, D.H., 2009. Accounting for spatial population structure in stock assessment: past, present, and future. *The future of fisheries science in North America*, 31, pp.405-426.
- Cailliet, G. M., E. K. Osada, and M. Moser. 1988. Ecological studies of sablefish in Monterey Bay. *Calif. Dept. Fish and Game* 74:133-153.
- Casillas, E., L. Crockett, Y. deReynier, J. Glock, M. Helvey, B. Meyer, and coauthors. 1998. Essential Fish Habitat, West Coast Groundfish. in Appendix to Amendment 11 of the Pacific Coast Groundfish Plan, Fishery Management Plan Environmental Impact Statement for the California, Oregon Washington Groundfish Fishery. National Marine Fisheries Service, Seattle.
- Cass, A., Beamish, R., and McFarlane, G. 1990. Lingcod (*Ophiodon elongatus*). *Canadian Special Publication of Fisheries and Aquatic Sciences* 109: 1–40.

- Checkley Jr., D.M. and Barth, J.A., 2009. Patterns and processes in the California Current System. *Progress in Oceanography*, 83(1-4), pp.49-64.
- Cope, J.M., 2004. Population genetics and phylogeography of the blue rockfish (*Sebastes mystinus*) from Washington to California. *Canadian Journal of Fisheries and Aquatic Sciences* 61, 332–342.
- Cope, J. M., D. Sampson, A. Stephens, M. Key, P. P. Mirick, M. Stachura, and coauthors. 2015. Assessments of Black Rockfish (*Sebastes melanops*) Stocks in California, Oregon, and Washington Coastal Waters. Pacific Fishery Management Council, Portland, OR.
- Cope, J.M. and Punt, A.E. 2009. Drawing the lines: resolving fishery management units with simple fisheries data. *Canadian Journal of Fisheries and Aquatic Sciences* 66: 1256–1273.
- Cope, J.M. and Punt, A.E. 2011. Reconciling stock assessment and management scales under conditions of spatially varying catch histories. *Fisheries Research* 107: 22–38. <https://doi.org/10.1016/j.fishres.2010.10.002>.
- Cope, J. M., T. Tsou, K. Hinton, and C. Niles. 2021. Status of vermilion rockfish (*Sebastes miniatus*) along the U.S. West - Washington State coast in 2021. Pacific Fishery Management Council, Portland, OR.
- Cope, J. M., and A. D. Whitman. 2021. Status of vermilion rockfish (*Sebastes miniatus*) along the U.S. West - Oregon coast in 2021. Pacific Fishery Management Council, Portland, OR.
- Cope, J. M., C. R. Wetzel, B. J. Langseth, and J. E. Budrick. 2021. Stock Assessment of the Squarespot Rockfish (*Sebastes hopkinsi*) along the California U.S. West Coast in 2021 using catch, length, and fishery-independent abundance data. Pacific Fishery Management Council, Portland, OR.
- Cope, J., E. J. Dick, A. MacCall, M. Monk, B. Soper, and C. Wetzel. 2014. Data-moderate stock assessments for brown, China, copper, sharpchin, stripetail, and yellowtail rockfishes and English and rex soles in 2013. Pacific Fishery Management Council, Portland, OR.
- Culver, B.N. 1987. Results of tagging black rockfish (*Sebastes melanops*) off the Washington and northern Oregon coast. In: *Proc. Int. Rockfish Symp.*, University of Alaska Sea Grant, AKSG-87-02.
- DeMott, G. E. 1982. Movement of tagged lingcod and rockfishes off Depoe Bay, Oregon.
- Dick, E. J., M. H. Monk, T. L. Rogers, J. C. Field, and E. M. Saas. 2021. The status of vermilion rockfish (*Sebastes miniatus*) and sunset rockfish (*Sebastes crocotulus*) in U.S. waters off the coast of California south of Point Conception in 2021. Pacific Fishery Management Council, Portland, OR.
- Dick, E. J., M. H. Monk, T. L. Rogers, J. C. Field, and E. M. Saas. 2021. The status of vermilion rockfish (*Sebastes miniatus*) and sunset rockfish (*Sebastes crocotulus*) in U.S. waters off

- the coast of California south of Point Conception in 2021. Pacific Fishery Management Council, Portland, OR.
- Dorval, E., Methot, R.D., Taylor, I.G. and Piner, K.R., 2022. Otolith chemistry indicates age and region of settlement of immature shortspine thornyhead *Sebastolobus alascanus* in the eastern Pacific Ocean. Marine Ecology Progress Series, 693, pp.157-175.
- Erickson, D.L. and Pikitch, E.K., 1993. A histological description of shortspine thornyhead, *Sebastolobus alascanus*, ovaries: structures associated with the production of gelatinous egg masses. Environmental biology of fishes, 36, pp.273-282.
- Fennie, H.W., Sponaugle, S., Daly, E.A. and Brodeur, R.D., 2020. Prey tell: what quillback rockfish early life history traits reveal about their survival in encounters with juvenile coho salmon. Marine Ecology Progress Series, 650, pp.7-18.
- Field, J.C., Miller, R.R., Santora, J.A., Tolimieri, N., Haltuch, M.A., Brodeur, R.D., Auth, T.D., Dick, E.J., Monk, M.H., Sakuma, K.M. and Wells, B.K., 2021. Spatiotemporal patterns of variability in the abundance and distribution of winter-spawned pelagic juvenile rockfish in the California Current. PloS one, 16(5), p.e0251638.
- Freiwald, J., 2012. Movement of adult temperate reef fishes off the west coast of North America. Canadian Journal of Fisheries and aquatic Sciences, 69(8), pp.1362-1374.
- Gao, Y., Svec, R.A., and Wallace, F.R. 2013. Isotopic signatures of otoliths and the stock structure of canary rockfish along the Washington and Oregon coast. Applied Geochemistry, 32: 70-75.
- Gertseva, V., Matson, S.E., and Cope, J. 2017. Spatial growth variability in marine fish: Example from Northeast Pacific groundfish. ICES Journal of Marine Science 74(6): 1602–1613.
- Gertseva, V. Taylor, I.G., Wallace, J.R., Matson, S.E. 2021. Status of the Pacific spiny dogfish shark resource off the continental U.S. Pacific Coast in 2021. Pacific Fishery Management, Portland, OR.
- Goethel, D.R., Quinn, T.J., and Cadrin, S.X., 2011. Incorporating spatial structure in stock assessment: movement modeling in marine fish population dynamics. Reviews in Fisheries Science, 19(2), pp.119-136.
- Goethel, D.R. and Berger, A.M., 2017. Accounting for spatial complexities in the calculation of biological reference points: effects of misdiagnosing population structure for stock status indicators. Canadian Journal of Fisheries and Aquatic Sciences, 74(11), pp.1878-1894. and Berger 2017)
- Gomez-Uchida, D., E. A. Hoffman, W. R. Ardren, and M. A. Banks. 2003. Microsatellite markers for the heavily exploited canary (*Sebastes pinniger*) and other rockfish species. Molecular Ecology 3(3):387-389.
- Gottscho, A.D., 2016. Zoogeography of the San Andreas Fault system: Great Pacific Fracture

- Zones correspond with spatially concordant phylogeographic boundaries in western North America. *Biological Reviews*, 91(1), pp.235-254.
- Green, K.M. and R.M. Starr. 2011. Movements of small adult black rockfish: implications for the design of MPAs. *Mar. Ecol. Prog. Ser.* 14: 219-230.
- Greenley, A.P. 2009. Movements of lingcod (*Ophiodon elongatus*) tagged in Carmel Bay, California. PhD thesis, San Jose State University.
- Guan, W., Cao, J., Chen, Y. and Cieri, M., 2013. Impacts of population and fishery spatial structures on fishery stock assessment. *Canadian Journal of Fisheries and Aquatic Sciences*, 70(8), pp.1178-1189.
- Gunderson, D., and R. Vetter., 2006, Temperate rocky reef fishes, in *Marine Metapopulations*, edited by P. Sale, and J. Kritzer, pp. 69– 117, Elsevier, Amsterdam.
- Haldorson, L., and Richards, L.J., 1987. Post-larval copper rockfish in the Strait of Georgia: habitat use, feeding, and growth in the first year. In *Proc. Int. Rockfish Symp.*, Univ. Alaska Sea Grant (pp. 129-141).
- Haltuch, M. A., K. Ono, and J. Valero. 2013. Status of the U.S. petrale sole resource in 2012. Pacific Fishery Management Council, Portland, OR.
- Hamilton, S., R. Starr, D. Wendt, B. Ruttenberg, J. Caselle, B. Semmens, L. Bellquits, S. Morgan, T. Mulligan, and J. Tyburczy. 2021. [California Collaborative Fisheries Research Program \(CCFRP\) – Monitoring and Evaluation of California Marine Protected Areas.](#)
- Hammer, C. and Zimmermann, C., 2005. The role of stock identification in formulating fishery management advice. In *Stock identification methods* (pp. 631-658). Academic Press.
- Hanan, D. and E Curry, B., 2012. Long-term movement patterns and habitat use of nearshore groundfish: tag-recapture in central and southern California waters. *The Open Fish Science Journal*, 5(1).
- Hannah, R.W., and Rankin, P.S. 2011. Site fidelity and movement of eight species of Pacific rockfish at a high-relief rocky reef on the Oregon coast. *North American Journal of Fisheries Management*, 31: 486-494.
- Hart, J. L. 1988. Pacific Fishes of Canada. *Bull. Fish. Res. Bd. Canada* 180: 1-730.
- Hartmann, A.R., 1987. Movement of scorpionfishes (Scorpaenidae, *Sebastes* and *Scorpaena*) In the Southern-California Bight. *California Fish and Game*, 73(2), pp.68-79.
- Hess, J.E., Vetter, R.D. and Moran, P., 2011. A steep genetic cline in yellowtail rockfish, *Sebastes flavidus*, suggests regional isolation across the Cape Mendocino faunal break. *Canadian Journal of Fisheries and Aquatic Sciences*, 68(1), pp.89-104.

- Hess, J.E., Hyde, J.R. and Moran, P. 2022. Comparative phylogeography of a bathymetrically segregated pair of sister taxa of rockfishes (genus *Sebastes*): black rockfish, *Sebastes melanops*, and yellowtail rockfish, *Sebastes flavidus*. <https://doi.org/10.21203/rs.3.rs-2203540/v1>.
- Hickey, B.M., 1979. The California current system—hypotheses and facts. *Progress in Oceanography*, 8(4), pp.191-279.
- Horn, M.H., Allen, L.G., and R.N. Lea. 2006. Biogeography, p. 3–25. In: Allen, L.G., Pondella, D.J., and Horn, M.H., eds. *The ecology of marine fishes: California and adjacent waters*. University of California Press. Berkeley, CA
- Hyde, J.R. and Vetter, R.D., 2007. The origin, evolution, and diversification of rockfishes of the genus *Sebastes* (Cuvier). *Molecular phylogenetics and evolution*, 44(2), pp.790-811.
- Hyde, J.R., Kimbrell, C.A., Budrick, J.E., Lynn, E.A. and Vetter, R.D. 2008a. Cryptic speciation in the vermilion rockfish (*Sebastes miniatus*) and the role of bathymetry in the speciation process. *Molecular Ecology*, 17(4), pp.1122-1136.
- Hyde, J.R., Kimbrell, C., Robertson, L., Clifford, K., Lynn, E. and Vetter, R., 2008b. Multiple paternity and maintenance of genetic diversity in the live-bearing rockfishes *Sebastes* spp. *Marine Ecology Progress Series*, 357, pp.245-253.
- Hyde, J. R., and R. D. Vetter. 2009. Population genetic structure in the redefined vermilion rockfish (*Sebastes miniatus*) indicates limited larval dispersal and reveals natural management units. *Can. J. Fish. Aquat. Sci.* 66(9): 1569-1581.
- Jacobson, L.D., and Vetter R. 1996. Bathymetric demography and niche separation of thornyhead rockfish: *Sebastolobus alascanus* and *Sebastolobus altivelis*. *Can. J. Fish. Aquat. Sci.* 53: 600–609.
- Johansson, M. L., M. A. Banks, K. D. Glunt, H. M. Hassel-Finnegan, and V. P. Buonaccorsi. 2008. Influence of habitat discontinuity, geographical distance, and oceanography on fine-scale population genetic structure of copper rockfish (*Sebastes caurinus*). *Molecular Ecology* 17(13): 3051-3061.
- Johnson, K. F., I. G. Taylor, B. J. Langseth, A. Stephens, L. S. Lam, M. H. Monk, and coauthors. 2021. Status of lingcod (*Ophiodon elongatus*) along the southern U.S. west coast in 2021. Pacific Fishery Management Council, Portland, OR.
- Kell, L.T., Dickey-Collas, M., Hintzen, N.T., Nash, R.D., Pilling, G.M. and Roel, B.A., 2009. Lumpers or splitters? Evaluating recovery and management plans for metapopulations of herring. *ICES Journal of Marine Science*, 66(8), pp.1776-1783
- Keller, A.A., Molton, K.J., Hicks, A.C., Haltuch, M., and Wetzel, C. 2012. Variation in age and growth of greenstriped rockfish (*Sebastes elongatus*) along the U.S. West coast (Washington to California). *Fisheries Research* 119-120: 80–88.

- Keller, A., Frey, P., Wallace, J., Head, M., Wetzel, C., Cope, J., and Harms, J. 2018. Canary rockfishes *Sebastes pinniger* return from the brink: Catch, distribution and life history along the US west coast (Washington to California). Marine Ecology Progress Series 599: 181–200.
- Kerr, L.A. and Goethel, D.R., 2014a. Simulation modeling as a tool for synthesis of stock identification information. In Stock identification methods (pp. 501-533). Academic Press.
- Kerr, L.A., Cadrin, S.X., Kovach, A.I., 2014b. Consequences of a mismatch between biological and management units on our perception of Atlantic cod off New England. ICES J. Mar. Sci. 71, 1366–1381.
- Kerr, L.A., Hintzen, N.T., Cadrin, S.X., Clausen, L.W., Dickey-Collas, M., Goethel, D.R., Hatfield, E.M., Kritzer, J.P. and Nash, R.D., 2017. Lessons learned from practical approaches to reconcile mismatches between biological population structure and stock units of marine fish. ICES Journal of Marine Science, 74(6), pp.1708-1722.
- Krigsman, L.M., 2000. A review of larval duration for Pacific coast temperate reef fishes, including kelp rockfish, *Sebastes atrovirens*. Senior thesis. Univ. California Santa Cruz.
- Laidig, T.E., Chess, J.R. and Howard, D.F., 2007. Relationship between abundance of juvenile rockfishes (*Sebastes* spp.) and environmental variables documented off northern California and potential mechanisms for the covariation. Fishery Bulletin, 105(1), pp.39-49.
- Largier, J.L., 2003. Considerations in estimating larval dispersal distances from oceanographic data. Ecological Applications, 13(sp1), pp.71-89
- Larson, R.J., Lenarz, W.H., and Ralston, S. 1994. The distribution of pelagic juvenile rockfish of the genus *Sebastes* in the upwelling region off Central California. CalCOFI Rep. 35: 175–219.
- Lam, L. S., B. L. Basnett, M. A. Haltuch, J. Cope, A. Kelly, K. M. Nichols, and coauthors. 2021. Geographic variability in lingcod (*Ophiodon elongatus*) life-history and demography along the US West Coast: Oceanographic drivers and management implications. Marine Ecology-Progress Series 670: 203-222.
- Lea, R.N., McAllister, R.D., and VenTresca, D.A. 1999. Biological aspects of nearshore rockfishes of the genus *Sebastes* from Central California with notes on ecologically related sport fishes. State of California The Resources Agency Department of Fish; Game.
- Langseth, B.J., C.R. Wetzel. 2021. Evaluating available information to inform stock management delineation for quillback rockfish (*Sebastes maliger*) off the U.S. West coast. Pacific Fishery Management Council, Portland, OR.
- Langseth, B. J., C. R. Wetzel, J. M. Cope, and J. E. Budrick. 2021a. Status of quillback rockfish (*Sebastes maliger*) in U.S. waters off the coast of California in 2021 using catch and length data. Pacific Fishery Management Council, Portland, OR.

- Langseth, B. J., C. R. Wetzel, J. M. Cope, T.-S. Tsou, and L. K. Hillier. 2021b. Status of quillback rockfish (*Sebastes maliger*) in U.S. waters off the coast of Washington in 2021 using catch and length data. Pacific Fishery Management Council, Portland, OR.
- Langseth, B. J., C. R. Wetzel, J. M. Cope, and A. D. Whitman. 2021c. Status of quillback rockfish (*Sebastes maliger*) in U.S. waters off the coast of Oregon in 2021 using catch and length data. Pacific Fishery Management Council, Portland, OR.
- Largier, J.L., 2003. Considerations in estimating larval dispersal distances from oceanographic data. *Ecological Applications*, 13(sp1), pp.71-89.
- Lefebvre, L.S., Friedlander, C.L. and Field, J.C., 2019. Reproductive ecology and size-dependent fecundity in the petrale sole (*Eopsetta jordani*) in waters of California, Oregon, and Washington. *Fishery Bulletin*, 117(4).
- Longo, G. C., L. Lam, B. Basnett, J. Samhoury, S. Hamilton, K. Andrews, and coauthors. 2020. Strong population differentiation in lingcod (*Ophiodon elongatus*) is driven by a small portion of the genome. *Evolutionary Adaptations* 13: 2536-2554.
- Longo, G.C., Harms, J., Hyde, J.R., Craig, M.T., Ramón-Laca, A., and Nichols, K.M., 2022. Genome-wide markers reveal differentiation between and within the cryptic sister species, sunset and vermilion rockfish. *Conservation Genetics*, pp.1-15.
- Lotterhos, K.E., Dick, S.J. and Haggarty, D.R., 2014. Evaluation of rockfish conservation area networks in the United States and Canada relative to the dispersal distance for black rockfish (*Sebastes melanops*). *Evolutionary Applications*, 7(2), pp. 238-259.
- Love, M. S. 1996. Probably more than you want to know about the fishes of the Pacific Coast. Really Big Press, Santa Barbara, California.
- Love, M.S. and Passarelli, J.K. eds., 2020. Miller and Lea's Guide to the Coastal Marine Fishes of California (Vol. 3556). UCANR Publications.
- Love, M. S., M. Yoklavich, and L. Thorsteinson. 2002. The rockfishes of the northeast Pacific. University of California Press, Berkeley, California.
- Lowe, C.G., Anthony, K.M., Jarvis, E.T., Bellquist, L.F., and Love, M.S. 2009. Site fidelity and movement patterns of groundfish associated with offshore petroleum platforms in the Santa Barbara Channel. *Marine and Coastal Fisheries* 1(1): 71–89.
- Markle, D.F., Harris, P.M., Toole, C.L., 1992. Metamorphosis and an overview of early-life-history stages in Dover sole *Microstomus pacificus*. *Fish. Bull.* 90: 285–301.
- Marko, P.B., Rogers-Bennett, L., and Dennis, A.B. 2007. MtDNA population structure and gene flow in lingcod (*Ophiodon elongatus*): Limited connectivity despite long-lived pelagic larvae. *Marine Biology* 150(6): 1301–1311.

- Mason, J. C., R. J. Beamish, and G. A. McFarlane. 1983. Sexual maturity, fecundity, spawning, and early life history of sablefish (*Anoplopoma fimbria*) in waters off the Pacific coast of Canada. *Canadian Journal of Fisheries and Aquatic Sciences* 40: 2621-2134.
- Matala, A.P., Gray, A.K., Gharrett, A.J. and Love, M.S., 2004. Microsatellite variation indicates population genetic structure of bocaccio. *North American Journal of Fisheries Management*, 24(4), pp.1189-1202.
- Matthews, K.R. 1990a. A telemetric study of the home ranges and homing routes of copper and quillback rockfishes on shallow rocky reefs. *Canadian Journal of Zoology* 68(11): 2243–2250.
- Matthews, K.R., 1990. An experimental study of the habitat preferences and movement patterns of copper, quillback, and brown rockfishes (*Sebastes* spp.). *Environmental Biology of Fishes*, 29, pp.161-178.
- McFarlane, G. A., and R. Beamish. 1983. Preliminary observations on the juvenile biology of sablefish (*Anoplopoma fimbria*) off the west coast of Canada. in *Proceedings of the International Sablefish Symposium*. Alaska Sea Grant Report 83-3.
- Methot, R. D., and K. Piner. 2002. Status of the canary rockfish resource off California, Oregon, and Washington in 2001. NWFSC/PFMC, Seattle, WA
- Methot, R. D., and I. J. Stewart. 2005. Status of the US canary rockfish resource in 2005. NWFSC/PFMC, Seattle, WA.
- MBC. 1987. Ecology of important fisheries species offshore California. Minerals Management Service, Pacific Outer Continental Shelf Region, Washington, D.C.
- Miller, D. J. and R. N. Lea. 1972. Guide to the coastal marine fishes of California. Calif. Dept. Fish and Game, Fish. Bull. 157: 249.
- Miller, J.A., Banks, M.A., Gomez-Uchida, D., Shanks, A.L., 2005. A comparison of population structure in black rockfish (*Sebastes melanops*) as determined with otolith microchemistry and microsatellite DNA. *Canadian Journal of Fisheries and Aquatic Sciences* 62: 2189–2198.
- Miller, J.A. and Shanks, A.L., 2004. Evidence for limited larval dispersal in black rockfish (*Sebastes melanops*): implications for population structure and marine-reserve design. *Canadian Journal of Fisheries and Aquatic Sciences*, 61(9), pp.1723-1735.
- Monk, M. H., E. J. Dick, J. C. Field, and T. L. Rogers. 2021. The status of vermilion rockfish (*Sebastes miniatus*) and sunset rockfish (*Sebastes crocotulus*) in U.S. waters off the coast of California north of Point Conception in 2021. Pacific Fishery Management Council, Portland, OR.
- Moser, H.G. 1974. Development and distribution of larvae and juveniles of *Sebastes* (Pisces; Family Scorpaenidae). *Fish Bull* 72: 865–884.

- Moser, H.G. 1996. The early stages of fishes in the California Current region. California Cooperative Oceanic Fisheries Investigations, Atlas No. 33. Allen Press, Inc., Lawrence, KS.
- NOAA (National Aeronautic and Atmospheric Administration). 1990. West coast of North America coastal and ocean zones strategic assessment: Data atlas. OMA/NOS, Ocean Assessments Division, Strategic Assessment Branch, NOAA.
- Ono, K., Shelton, A.O., Ward, E.J., Thorson, J.T., Feist, B.E., and Hilborn, R. 2016. Spacetime investigation of the effects of fishing on fish populations. *Ecological Applications* 26(2): 392–406.
- Ottmann, D., Grorud-Colvert, K., Huntington, B. and Sponaugle, S., 2018. Interannual and regional variability in settlement of groundfishes to protected and fished nearshore waters of Oregon, USA. *Marine Ecology Progress Series*, 598, pp.131-145.
- Pacific Fishery Management Council (PFMC). 2022a. Amendment 30 to the Pacific Coast Groundfish Fishery Management Plan, 2023-2024 Harvest Specifications, and Management Measures. Pacific Fishery Management Council. Portland, OR 97220.
- PFMC. 2022b. Status of the Pacific Coast Groundfish Fishery: Stock Assessment and Fishery Evaluation. Pacific Fishery Management Council. Portland, OR 97220.
- PFMC. 2022c. Terms of Reference for the Groundfish Stock Assessment Review Process for 2023-2024. Pacific Fishery Management Council. Portland, OR 97220.
- PFMC. 2020. Amendment 29 to the Pacific Coast Groundfish Fishery Management Plan and 2021-22 Harvest Specifications and Management Measures. Pacific Fishery Management Council. Portland, OR 97220.
- PFMC. 2018. Pacific Coast Groundfish Fishery 2019–20 Harvest Specifications, Yelloweye Rebuilding Plan Revisions, and Management Measures. Pacific Fishery Management Council. Portland, OR 97220.
- PFMC. 2018. Pacific Coast Groundfish Fishery 2019–20 Harvest Specifications, Yelloweye Rebuilding Plan Revisions, and Management Measures. Pacific Fishery Management Council. Portland, OR 97220.
- PFMC. 2016. 2017-2018 Groundfish Harvest Specifications and Management Measures including changes to Groundfish Designations (Amendment 27 to the Pacific Coast Groundfish Fishery Management Plan. Pacific Fishery Management Council. Portland, OR 97220.
- PFMC. 2015. Final Environmental Impact Statement for Harvest Specifications and Management Measures for 2015-2016 and Biennial Periods Thereafter; Includes the Reorganization of Groundfish Stock Complexes, Designation of Ecosystem Component Species and Amendment 24 to the Pacific Coast Groundfish Fishery Management Plan to Establish a Process for Determining Default Harvest Specifications. Pacific Fishery Management Council. Portland, OR 97220.

- Parker, S.J., P.S. Rankin, J.M. Olson, and R.W. Hannah, R.W. 2007. Movement patterns of black rockfish *Sebastes melanops* in Oregon coastal waters. In Heifetz, J., DiCosimo, J., Gharrett, A.J., Love, M.S., O'Connell, V.M., and Stanley, R.D. (editors), *Biology, Assessment, and Management of North Pacific Rockfishes*. Alaska Sea Grant College Program.
- Parrish, R.H., Nelson, C.S. and Bakun, A., 1981. Transport mechanisms and reproductive success of fishes in the California Current. *Biological Oceanography*, 1(2), pp.175-203.
- Pearcy, W.G., Hosie, M.J., Richardson, S.L. 1977. Distribution and duration of pelagic life of larvae of Dover sole, *Microstomus pacificus*; rex sole, *Glyptocephalus zachirus*; and petrale sole, *Eopsetta jordani*, in waters off Oregon. *Fish. Bull.* 75: 173–183.
- Pearson, K.E. and Gunderson, D.R., 2003. Reproductive biology and ecology of shortspine thornyhead rockfish, *Sebastolobus alascanus*, and longspine thornyhead rockfish, *S. altivelis*, from the northeastern Pacific Ocean. *Environmental Biology of Fishes*, 67, pp.117-136.
- Petrie, M., and Ryer, C. 2006. Hunger, light level and body size affect refuge use by post settlement lingcod (*Ophiodon elongatus*). *Journal of Fish Biology* 69(4): 957–969.
- Phillips, J.B., 1957. A review of the rockfishes of California (family Scorpaenidae) California Department of Fish and Game Bulletin, No 104, 158 p.
- Phillips, A.C., and Barraclough, W.E. 1977. On the early life history of the lingcod (*Ophiodon elongatus*). Pacific Biological Station, Fisheries; Marine Service, Department of Fisheries & Oceans Canada.
- Phillips, J. B. and S. Inamura. 1954. The sablefish fishery of California. *Pac. Mar. Fish. Comm. Bull.* 3: 5-38.
- Piner K.R. and R.D. Methot. 2001. Stock status of shortspine thornyhead off the Pacific west coast of the United States 2001. SAFE 2001, Pacific Fisheries Management Council, Portland, OR.
- Punt, A.E., M. Haddon, L.R. Little, G.N. Tuck. 2016. Can a spatially-structured stock assessment address uncertainty due to closed areas? A case study based on pink ling in Australia? *Fish. Res.* 175, 10-23.
- Punt, A. E. 2019. Spatial stock assessment methods: A viewpoint on current issues and assumptions. *Fisheries Research*, 213, 132–143.
- Punt, A.E., M. Haddon, L.R. Little, G.N. Tuck. 2016. Can a spatially-structured stock assessment address uncertainty due to closed areas? A case study based on pink ling in Australia? *Fish. Res.* 175, 10-23.

- Ralston S. and E.J. Dick. 2003. The status of black rockfish (*Sebastes melanops*) off Oregon and northern California in 2003. Pacific Fishery Management Council, Portland, OR.
- Ralston, S., Sakuma, K.M. and Field, J.C., 2013. Interannual variation in pelagic juvenile rockfish (*Sebastes* spp.) abundance—going with the flow. *Fisheries Oceanography*, 22(4), pp.288-308.
- Rankin, P.S., Hannah, R.W., and Blume, M.T., 2013. Effect of hypoxia on rockfish movements: implications for understanding the roles of temperature, toxins and site fidelity. *Marine Ecology Progress Series*, 492, pp.223-234.
- Reynolds, B.F., Powers, S.P. and Bishop, M.A., 2010. Application of acoustic telemetry to assess residency and movements of rockfish and lingcod at created and natural habitats in Prince William Sound. *PloS one*, 5(8), p.e12130.
- Richards, L. J., J. T. Schnute, and C. M. Hand. 1990. A multivariate maturity model with a comparative analysis of three lingcod (*Ophiodon elongatus*) stocks. *Can. J. Fish. Aquat. Sci.* 47(5):948-959.
- Rochas-Olivares, A. and Vetter, R.D., 1999. Effects of oceanographic circulation on the gene flow, genetic structure, and phylogeography of the rosethorn rockfish (*Sebastes helvomaculatus*). *Canadian Journal of Fisheries and Aquatic Sciences*, 56(5), pp.803-813. and Vetter, 1999)
- Rousset, F., 1997. Genetic differentiation and estimation of gene flow from F-statistics under isolation by distance. *Genetics*, 145(4), pp.1219-1228.
- Sakuma, K.M., Bjorkstedt, E.P. and Ralston, S., 2013. Distribution of pelagic juvenile rockfish (*Sebastes* spp.) in relation to temperature and fronts off central California. *California Cooperative Oceanic Fisheries Investigations Reports*, 54, pp.167-179.
- Sampson, D. B. 1996. Stock Status of Canary Rockfish off Oregon and Washington. *In* Status of the Pacific coast groundfish fishery through 1996 and recommended acceptable biological catches for 1997: stock assessment and fishery evaluation. Pacific Fishery Management Council, Portland, Oregon.
- Sampson, D.B. 2007. The Status of Black Rockfish off Oregon and California in 2007. Pacific Fishery Management Council, Portland, OR.
- Schroeder, I.D., Santora, J.A., Bograd, S.J., Hazen, E.L., Sakuma, K.M., Moore, A.M., Edwards, C.A., Wells, B.K. and Field, J.C. 2019. Source water variability as a driver of rockfish recruitment in the California Current Ecosystem: implications for climate change and fisheries management. *Canadian Journal of Fisheries and Aquatic Sciences*, 76(6), pp.950-960.
- Schwenke, P.L., L.K Park, and L. Hauser. 2018. Introgression among three rockfish species (*Sebastes* spp.) in the Salish Sea, northeast Pacific Ocean. *PloS one*, 13(3), p.e0194068.

- Secor, D.H., 2015. The unit stock concept: bounded fish and fisheries. In Stock identification methods (pp. 7-28). Academic Press.
- Seeb, L. W. 1998. Gene flow and introgression within and among three species of rockfishes, *Sebastes auriculatus*, *S. Caurinus* and *S. Maliger*. *Journal of Heredity* 89(5):393-403.
- Siebenaller, J. F. and G. N. Somero. 1982. The Maintenance of Different Enzyme Activity Levels in Congeneric Fishes Living at Different Depths. *Physiological Zoology* 55:171-179.
- Siebenaller, J.F. 1978. Genetic variability in deep-sea fishes of the genus *Sebastolobus* (Scorpaenidae). In *Marine Organisms*, Edited by B. Battaglia and J. Beardmore. Plenum Press, New York, pp. 95-122.
- Silberberg, K. R., T. E. Laidig, P. B. Adams, and D. Albin. 2001. Analysis of maturity in lingcod, *Ophiodon elongatus*. *California Department of Fish and Game* 87(139-152).
- Sivasundar, A. and S. R. Palumbi. 2010. Life history, ecology and the biogeography of strong genetic breaks among 15 species of Pacific rockfish, *Sebastes*. *Marine Biology* 157(7): 1433-1452.
- Stahl, J., Green, K., & Vaughn, M. (2014). Examination of Lingcod, *Ophiodon elongatus*, Movements in Southeast Alaska Using Traditional Tagging Methods. *Game, Fishery Data Series*, No. 14–28
- Starr, R.M. and Green, K., 2007. [Groundfish Cooperative Research Project](#).
- Starr, R.M., O'Connell, V., Ralston, S., and Breaker, L. 2005. Use of acoustic tags to estimate natural mortality, spillover, and movements of lingcod (*Ophiodon elongatus*) in a marine reserve. *Marine Technology Society Journal* 39(1): 19–30
- Stawitz, C. C., F. Hurtado-Ferro, P. Kuriyama, J. T. Trochta, K. F. Johnson, M. A. Haltuch, and coauthors. 2015. Stock assessment update: Status of the U.S. petrale sole resource in 2014. Pacific Fishery Management Council, Portland, OR.
- Stein, D. and T.J. Hassler. 1989. Species profiles: Life histories and environmental requirements of coastal fishes and invertebrates (Pacific southwest): Brown rockfish, copper rockfish, black rockfish.: U.S. Fish and Wildlife Service Biological Report 82: (11.113).
- Stepien, C.A. 1995. Population genetic divergence and geographic patterns from DNA sequences: examples from marine and freshwater fishes. *Am Fish Soc Symp* 17: 263–287.
- Stepien, C. 1999. Phylogeographical structure of the Dover sole, *Microstomus pacificus*: The larval retention hypothesis and genetic divergence along the deep continental slope of the northeastern Pacific Ocean. *Molecular Ecology* 8(6): 923–939.
- Stepien, CA, Dillon, AK, and A.K. Patterson. 2000. Population genetics, phylogeography, and systematics of the thornyhead rockfishes (*Sebastolobus*) along the deep continental slopes of the North Pacific Ocean. *Can J Fish Aquat Sci* 57: 1701–1771.

- Stewart, I. J. 2009. Status of the US canary rockfish resource in 2009 (Update of 2007 assessment model). Northwest Fisheries Science Center, National Marine Fisheries Service, Seattle, WA.
- Stout, H. A., B. B. McCain, R. D. Vetter, T. L. Builder, W. H. Lenarz, L. L. Johnson, and coauthors. 2001. Status review of copper rockfish (*Sebastes caurinus*), quillback rockfish (*S. maliger*), and brown rockfish (*S. auriculatus*) in Puget Sound, Washington. NOAA Tech.Memo NMFS-NWFSC; 46.
- Strub, P.T., Allen, J.S., Huyer, A., and Smith, R.L. 1987. Seasonal cycles of currents, temperatures, winds, and sea level over the northeast Pacific continental shelf: 35°N to 48°N. J. Geophys. Res. 92: 1507–1526.
- Taylor, C.A. 2004. Patterns of Early-State Pelagic Dispersal and Gene Flow in Rockfish Species from the Southern California Bight. UC San Diego: California Sea Grant College Program.
- Taylor, I.G. 2008. Modeling spiny dogfish population dynamics in the Northeast Pacific. Ph.D. Dissertation. University of Washington.
- Taylor I.G. and A. Stephens. 2014. Stock assessment of shortspine thornyhead in 2013. Pacific Fishery Management Council, Portland, OR.
- Taylor, I.G., K.F. Johnson, B.J. Langseth, A. Stephens, L.S. Lam, M.H. Monk, and coauthors. 2021. Status of lingcod (*Ophiodon elongatus*) along the northern U.S. west coast in 2021. Pacific Fishery Management Council, Portland, OR.
- Taylor, I.G. and A. Stephens. 2014. Stock Assessment of Shortpine Thornyhead in 2013. Pacific Fishery Management Council, Portland, OR.
- Thorson, J. T. and C. Wetzel. 2016. The status of canary rockfish (*Sebastes pinniger*) in the California Current in 2015. Pacific Fishery Management Council, Portland, OR.
- Tolimieri and Levin, N. and Levin, P.S., 2006. Assemblage structure of eastern Pacific groundfishes on the US continental slope in relation to physical and environmental variables. Transactions of the American Fisheries Society, 135(2), pp.317-332.
- Tolimieri, N., 2007. Patterns in species richness, species density, and evenness in groundfish assemblages on the continental slope of the US Pacific coast. Environmental Biology of Fishes, 78, pp.241-256
- Tolimieri, N., Andrews, K., Williams, G., Katz, S., and Levin, P. 2009. Home range size and patterns of space use by lingcod, copper rockfish and quillback rockfish in relation to diel and tidal cycles. Marine Ecology Progress Series 380: 229–243.

- Tolimieri, N., Wallace, J., and Haltuch, M. 2020. Spatio-temporal patterns in juvenile habitat for 13 groundfishes in the California Current Ecosystem. PLOS ONE 15: e0237996.
- Wakefield, W.W. 1990. Patterns in the distribution of demersal fishes on the upper continental slope off central California with studies on the role of ontogenetic vertical migration in particle flux. PhD thesis, University of California, San Diego, CA.
- Wakefield, W.W. and K.L. Smith. 1990. Ontogenetic vertical migration in *Sebastolobus altivelis* as a mechanism for transport of particulate organic matter at continental slope depths. Limnol. Oceanogr. 35: 1314–1328.
- Wallace, F.R., Hoffmann, A. and Tagart, J., 1999. Status of the black rockfish resource in 1999. Pacific Fishery Management Council, Portland, OR.
- Wallace, F., Cheng, Y.W. and Tsou, T.S., 2008. Status of the black rockfish resource north of Cape Falcon, Oregon to the US-Canadian border in 2006. Pacific Fishery Management Council, Portland, OR.
- Wallace, J. R., and J. M. Cope. 2011. Status update of the US canary rockfish resource in 2011. Pacific Fishery Management Council, Portland, OR.
- Wallace, F., T.S. Tsou, Y.W. Cheng, L. Wargo. 2010. Summary of the coastal black rockfish tagging program 1981-2008. State of Washington Department of Fish and Wildlife. Technical report No. FPT 11-02.
- Westrheim, S.J., Barss, W.H., Pikitch, E.K., and Quirollo, L.F. 1992. Stock delineation of Dover sole in the California-British Columbia region, based on tagging studies conducted during 1948-1979. North American Journal of Fisheries Management 12: 172-181.
- Wetzel, C. R. 2019. Status of petrale sole (*Eopsetta jordani*) along the U.S. west coast in 2019. Pacific Fishery Management Council, Portland, OR.
- Wetzel, C. R. and A. M. Berger. 2021. Status of Dover sole (*Microstomus pacificus*) along the U.S. West Coast in 2021. Pacific Fishery Management Council, Portland, OR.
- Wetzel, C. R., B. J. Langseth, J. M. Cope, and J. E. Budrick. 2021a. The status of copper rockfish (*Sebastes caurinus*) in U.S. waters off the coast of California north of Point Conception in 2021 using catch and length data. Pacific Fishery Management Council, Portland, OR.
- Wetzel, C. R., B. J. Langseth, J. M. Cope, and J. E. Budrick. 2021b. The status of copper rockfish (*Sebastes caurinus*) in U.S. waters off the coast of California south of Point Conception in 2021 using catch and length data. Pacific Fishery Management Council, Portland, OR.
- Wetzel, C. R., B. J. Langseth, J. M. Cope, T.-S. Tsou, and K. E. Hinton. 2021c. Status of copper rockfish (*Sebastes caurinus*) in U.S. waters off the coast of Washington in 2021 using catch and length data. Pacific Fishery Management Council, Portland, OR.

- Wetzel, C. R., B. J. Langseth, J. M. Cope, and A. D. Whitman. 2021d. The status of copper rockfish (*Sebastes caurinus*) in U.S. waters off the coast of Oregon in 2021 using catch and length data. Pacific Fishery Management Council, Portland, OR.
- Wishard, L. N., F. M. Utter & D. R. Gunderson. 1980. Stock separation of five rockfish species using naturally occurring biochemical genetic markers. *Mar. Fish. Rev.* 42: 64–73.
- Wyllie-Echeverria, T. 1987. Thirty-four species of California rockfishes: maturity and seasonality of reproduction. *NOAA Fish. Bull.* 85(2): 229-250.
- Ying, Y., Chen, Y., Lin, L. and Gao, T., 2011. Risks of ignoring fish population spatial structure in fisheries management. *Canadian Journal of Fisheries and Aquatic Sciences*, 68(12), pp.2101-2120.
- Zipkin, E. F., and Saunders, S. P. 2018. Synthesizing multiple data types for biological conservation using integrated population models. *Biological Conservation*, 217, 240–250

8. Contributors

Todd Phillips	Primary Author, Pacific Fishery Management Council
Gretchen Hanshaw	Primary Author, NMFS West Coast Region
Marlene Bellman	Primary Author, Pacific Fishery Management Council
Dr Jason Cope	Science Advisor, NMFS Northwest Science Center
Dr John Field	Science Advisor, NMFS Southwest Science Center
Dr. Brian Langseth	Science Advisor, NMFS Northwest Science Center
Dr Chantel Wetzel	Science Advisor, NMFS Northwest Science Center

Appendix A: Biological Information

Appendix A Synthesis

This appendix is a detailed literature review which investigates overarching considerations regarding population dynamics as well as biological information for each species considered in this action. The following summarizes key points of Appendix A.

The SSC had extensive discussions in November 2021 on information to use when aggregating assessments for status determination ([Agenda Item E.3.a, Supplemental SSC Report 1, November 2021](#)). While this discussion occurred prior to the stock definitions action, their recommendations in that statement are germane to how the following analysis attempts to define groundfish populations as stocks. The SSC recommended that when considering population structure, that the most conclusive sources of information are typically genetic differences if they exist, less conclusive information is exchange/movement of adults, followed by larval dispersal ([Agenda Item E.3.a, Supplemental SSC Report 1, November 2021](#)). The lowest tier was demographic differences, such as size at age.

The one oft-used attribute is genetic differentiation. When members of a fish species are segregated into multiple reproductive stocks, allele frequencies at neutral genetic markers diverge under genetic drift such that the variance in gene frequencies reflects the magnitude of reproductive isolation among these stocks. Thus, gene frequency differences among geographic samples can be used to indirectly estimate patterns of gene flow and hence population structure of the species. Genetic differences often provide signals on long-time scales (e.g., geologic), and thus can miss more recent and relevant time scales unless extremely sensitive markers are used. Population connectivity by measuring dispersal and movement (which can also be done using natural markers, such as in otolith microchemistry studies) in at least one stage of the life cycle is a more direct way to measure contemporaneous connections among subpopulations along a species range (Gunderson and Vetter, 2006).

Homogeneous population structure assumes there is connectivity in the population, meaning reproductive units within the population are not isolated from one another. It only takes exchange in a few individuals to cause this homogeneity using genetic markers, though this type of population structure may also suggest high mixing patterns in terms of larvae, juveniles, and/or adults along the species range. In brief, evidence suggests that individuals in homogeneous populations are not isolated from one another on the geographic scale i.e., the population is connected. Heterogeneous population structure assumes the converse, with low connectivity caused by life history, geographic, and/or oceanographic constraints. Within a heterogeneous population, there would be identifiable subpopulations that are likely reproductively isolated from other subpopulations. Reproductively isolated subpopulations are known to show genetic

differences, suggesting limited connectivity along the species range. This analysis considers species with homogeneous populations as interrelated single species (ISS)²⁸ populations.

Population connectivity is not the only criterion to use for defining a stock. Ideally, a stock should consist of a collection of individuals that interact enough to create a coherent population trend (i.e., have the same population dynamics). This defines subpopulations as from the same stock if they demonstrate comparable recruitment patterns, life history values and exploitation histories, thus exhibiting similar population trends (Cope and Punt, 2009; 2011). In fact, exploitation history alone can cause localized depletion events despite total population connectivity via larval dispersal or adult movements. Ignoring this can lead to mismanagement of stocks (Cope and Punt, 2011), thus providing spatially-resolved population assessments when considering each of the factors can provide the most appropriate resolution to set catch limits.

Many of the species considered in this action are nearshore fishes. Nearshore rockfishes, in particular, are known to be rocky reef and kelp forest dependent, thus associated with patchy habitat along a long latitudinal stretch. Within that long latitude it is not uncommon to encounter gradients in biology and differential exploitation histories (Gertseva et al., 2017; Lam et al., 2021). In addition, nearshore fishes often demonstrate low larval dispersal as larvae are often retained close to shore and settle in the nearshore environment (Larson et al., 1994; Love et al., 2002, Largier, 2003; Gunderson and Vetter, 2006). This dispersal range of many nearshore rockfishes is thought to be small (on the order of 10 to perhaps 100s of kms) but those metrics are highly uncertain (Baetscher et al., 2019; Buonaccorsi et al., 2004; Miller and Shanks, 2004; Miller et al., 2005). It is thus very common to encounter stepping-stone or isolation by distance genetic models among nearshore stocks (Buonaccorsi et al., 2002; Cope, 2004; Bernston and Moran, 2008).

Literature suggests there are multiple sub-populations of nearshore rockfish species along the coast that may be isolated by distance from one another (Bernston and Moran, 2008). Populations isolated from one another indicate that there may be low connectivity between them. Species with distinct (heterogeneous) population structure are likely not single populations, which assumes no discernible (homogeneous) population structure.

Assessments attempt to model population dynamics at a geographic scale that is informed by BSIA for population structure. Meaning, a coastwide assessment assumes the population is homogeneous throughout its west coast range and assessments at the less than coastwide scale assumes the population is heterogeneous. In heterogeneous populations, assessors often use state boundaries to delineate sub-areas (e.g., quillback rockfish), though sub-areas can be based on more discrete biogeographical data (e.g., vermilion/sunset rockfish north and south of Point Conception [34°27' N. lat.]). These sub-areas are informed by BSIA. Population delineations can also be informed by data availability, history of fishery exploitation, etc. Population breaks can often correspond to biogeographic boundaries that occur within state lines (Keller et al., 2018; Brooks, 2021). Spatially explicit assessment methods that reflect population structure, as well as incorporate fishery

²⁸ This terminology is somewhat different from what is presented in the Alternative 1 language from the motion, where coastwide is used instead of the term interrelated single stock. We recommend the language change to interrelated single stock (ISS) based on the Groundfish Management Team's [November 2022 H.5.a Report](#) recommendation where they note the term "coastwide" implies the stock's range is the entire West Coast (Canada to Mexico); however, while this range may apply to multiple species, not all have that geographic range (e.g., squarespot rockfish).

exploitation data at the same scale, likely increase the understanding of the species as well as improve managers ability to maintain a sustainable resource (Brooks, 2021).

Appendix A: Biological Information compiles this information for the priority species and is incorporated through reference throughout this analysis. Structure indicates population connectivity. In general, high connectivity implies a single connected unit of fish across the species' range (i.e., a single stock); whereas, low connectivity implies isolated, unconnected units of fish across species' range homogeneous population (i.e., multiple stocks). Population structure can be determined on a geographic basis, giving a base method to determine geographical boundaries for the population.

Synthesis of Spatial Population Structure Literature

There is extensive literature describing the progression of knowledge around understanding the spatial structure of fishery populations, how to incorporate that knowledge into assessments, and how that knowledge can inform management. Cadrin and Secor (2009) describe this progression for assessments from early assumptions of homogeneity to more complex concepts of spatial and temporal variability. Hammer and Zimmerman (2005) discuss that management units have traditionally grown and are not adjusted to either the changes in distribution of stocks or to the change of scientific perception of the particular stock boundaries. In recent years, there has been an increase in the application of simulation models to evaluate alternative approaches to address misalignment of biological and management units (e.g., Kell et al., 2009; Cope and Punt, 2011; Ying et al., 2011; Kerr et al., 2014b, Berger et al. 2021).

Understanding the spatiotemporal scale of population structure for a species in relation to management units is important for effective long-term sustainable management (Goethel et al., 2011). Most species demonstrate variability in life history characteristics, uneven distributions across a species range, and connectivity across population components that can lead to different responses to harvest (Kerr et al., 2017; Zipkin and Saunders, 2018; Punt, 2019). Not accounting for differences in these characteristics when they exist can result in inaccurate estimates of stock productivity and sustainable yield and misinterpretation of trends in abundance (e.g., Kerr et al., 2014a; Secor, 2015). Kerr et al. (2014) found that the Atlantic cod populations located off the northeastern United States appeared more robust to fishing pressure when management boundaries were used rather than the correct biological stock delineations, which could lead to overfishing. Spawning biomass and fishing mortality rate were also biased for Atlantic herring when management boundaries were used to assess population status rather than biological boundaries (Guan et al., 2013). Berger et al. (2021) found increased bias in estimates of terminal spawning biomass as management areas misaligned with biological areas. This bias increased when fishing mortality was disproportionate to vulnerable biomass, demographic parameters were not homogenous, and connectivity existed between the management areas and was not accounted for (Berger et al., 2021). Altogether, the situations described in the above papers create barriers to successful management such as increased risk for local depletion, inappropriate allocations of catch across regions, loss of sustainable yield, and overall biased estimates informing decisions.

A particular concern with assuming no population structure when in fact population structure exists is with localized dynamics. Although system-wide biomass was found to be unbiased when assumptions about spatial structure did not align with the underlying dynamics, looking only at system-wide biomass or assuming a single homogeneous areas masked localized depletion

(Goethel and Berger, 2017; Bosley et al., 2019; Berger et al., 2021). Consequently, if a coastwide population is assumed, but the underlying population is structured at a finer scale, there are risks that localized depletion can occur.

The above examples emphasize the importance of aligning management boundaries with the underlying biological dynamics. Kerr et al. (2017) noted that management units usually cannot exactly match biological boundaries, because the latter are not precisely known and do not have abrupt edges, and the spatial resolution of fishery management (e.g., reporting of fishing effort, monitoring of catch, and enforcement of regulations) is limited. However, key elements can be incorporated and the literature consulted to ensure setting of management boundaries follows the best scientific information available.

Kerr et al. (2017) outline a process for updating management and assessment considerations in relation to population structure. The first step of that process involves a “holistic review of available stock identity information by a group of experts.” Cadrin et al. (2014) describes the elements of such a holistic review as including the following steps:

- i. Clearly define the current spatial management units and their scientific or practical justification.
- ii. Identify all a priori hypotheses about population structure, including the paradigm used to justify current management units.
- iii. Conduct a comprehensive review of information related to the specific fishery resource being evaluated, ideally considering information from throughout the species’ geographic range.
- iv. Synthesize the information available within each discipline with respect to population structure and the stated hypotheses and evaluate the perception of population structure across the disciplines.
- v. Consider each a priori hypothesis, the information that rigorously tested the hypotheses, and whether the information could be used to either reject or support hypotheses. Draw final conclusions on biological stocks based on the most robust and parsimonious view of population structure that is consistent with the best scientific information available.

The International Council for the Exploration of the Sea (ICES) Stock Identification Methods Working Group is an example of such a group, with representatives from diverse fields, and updates best practices related to identifying stocks in the Atlantic Ocean (Cadrin, 2020).

Cadrin (2020) provides additional considerations when identifying stocks. These include three broad categories of data including spatial distribution, dispersal, and geographic variation, each of which contain multiple sub-categories. A few sub-categories include adult and larval distribution for dispersal, and patterns in life history traits, abundance, size composition, and genetics for geographic variation. Both Kerr et al. (2017) and Cadrin (2020) stress the importance of interdisciplinary identification of stocks to both increase the chance of correctly identifying population structure and also to account for information across ecological and evolutionary time scales that the different disciplines capture.

Identifying population structure requires fine scale data that does not always exist. Assuming population structure based on imperfect information does have risks. Through simulation Punt et al. (2016) showed some of the consequences of assuming spatial structure but still missing critical differences. Models capturing all spatial differences between two areas performed best among simulations, but assuming spatial structure, yet incorrectly assuming constant growth between the areas, performed no better than assuming a single homogeneous area. This contrasts with Bosely et al. (2022) who found allowing for spatial population structure is likely to be less detrimental than ignoring it completely. Bosley et al. (2022) found that allowing assessments flexibility in movement estimation could mitigate against the risk of not knowing the correct underlying spatial structure.

Large and fine scale habitat and oceanographic features are often considered to be key drivers of population or stock structure for marine species, where such structure exists. Within the California Current ecosystem, the nearshore, shelf, slope and offshore regions generally have their greatest changes in physical and biological characteristics at major promontories, with Point Conception (34°27' N. lat.), Cape Mendocino (40°30' N. lat.), and Cape Blanco (42°50' N. lat.) generally considered to be among the most important biogeographic features along the U.S. West coast (Hickey, 1979; Checkley and Barth, 2009; Gottscho, 2014). These features typically reflect strong shifts in biological community structure and other ecological features (Horn et al., 2006; Tolimieri and Levin, 2006; Tolimieri, 2007) as well as often being regions in which greater genetic diversity within species is observed (Sivasundar and Plumbi, 2010; Hess et al., 2011; others). However, within species or populations, differences in depth and habitat distributions, seasonality of reproduction, larval durations and both juvenile and adult movement patterns also factor into the degree of population structure or connectivity over larger spatial scales, and a wide range of potential population structure “types” is possible depending on a suite of life history factors.

Gunderson and Vetter (2006) built on previous analyses to develop a useful conceptual model for a suite of plausible population structure types for rocky reef fishes throughout the Northeast Pacific (i.e., U.S. West coast north through the Gulf of Alaska). They suggest four primary types of population structures that are useful to consider in this analysis. In the first, there is broad dispersal of larvae throughout most or all of the Northeast Pacific, and consequently little to no population structure. They suggest that this is likely to be a reasonable conceptual model for many deep-water species for which spawning occurs in deep or offshore waters, and larval duration can be extensive (a year or more), such as the thornyheads or Dover sole. In a second, major biogeographic features (such as Cape Mendocino, Point Conception, and the northern tip of Vancouver Island) help to define population structure by limiting (but not eliminating) dispersal across these oceanographic domains. Their review suggests that this is likely to be the most appropriate model for many shelf and some nearshore rockfishes, and indeed this is consistent with many genetic population structure studies (e.g., Rochas-Olivares and Vetter, 1999; Hess et al., 2011; others). Their third model reflects “diffusive dispersal” in which nearshore species, particularly those associated with kelp forests and with shorter larval durations, are subject to more constraining advective processes, such as “sticky water” zones in which larvae tend to be entrained in nearshore water masses that are rarely advected offshore or great distances (Largier, 2003). The fourth model is described as “non-dispersing,” and relates primarily to a very limited number of species with high parental investment and no larval or juvenile dispersal stages, such as some elasmobranchs and live bearing surfperches.

Priority Species Literature Review

A key first step in defining stocks is understanding the species biology. The SSC recommended at least three tiers of biological attributes to consider when deciding a stock definition ([Agenda Item E.3.a, Supplemental SSC Report 1, November 2021](#)). The highest tier of these attributes is a genetic difference among meaningful markers. The next highest tier of information is exchange or movement of adults, followed by larval dispersal between areas. The lowest tier of information is differences in demographic characteristics ([Agenda Item H.5, Attachment 1, November 2022](#)).

The following priority species descriptions summarizes the current knowledge surrounding population structure of the priority species by expanding on Table 1 in [Agenda Item H.5, Attachment 1, November 2022](#). In our investigation we examine genetic information, adult, juvenile, and larval movement, demographic information as well as past assessment stratification. This information originates from current scientific literature, the [2022 Groundfish Stock Assessment and Fishery Evaluation \(SAFE\) document](#), and from the species-specific [assessments](#). The majority of the species detailed below have ranges that exceed the U.S./Mexico and/or the U.S./Canada borders; however, assessments focus only on the populations off of the U.S. West coast, though posit on potential connectivity to other populations. Some of these species could be considered sub-populations of a larger population (or metapopulation) that extends beyond the U.S. given their geographic extent. While the following centers on the scientific rationale for stock definitions, the Council could consider other issues as relayed in National Standards guidance. Implications regarding defining these populations are discussed under the Alternative analyses.

We note all of the 2021 assessments, as well as past assessments of the following priority species, have previously been endorsed as BSIA by the SSC and NMFS. While U.S. West coast populations of these species do not have officially defined stock units in the FMP, the assessments treat the populations as de facto stocks and have developed harvest specifications based on these assumed units. To date, the Council has managed to apply these harvest specifications to inform management decisions under the same assumption.

Black rockfish

Black rockfish (*Sebastes melanops*) range from Southern California (San Miguel Island) to the Aleutian Islands in Alaska (Amchitka Island), and they occur most commonly from San Francisco northward (Phillips, 1957; Miller and Lea, 1972; Hart, 1988; Stein and Hassler, 1989). Black rockfish are key targets of recreational fisheries from central California to Alaska and are a major presence in nearshore rocky reefs systems in those areas.

Genetic studies have found evidence that there may be at least three populations along the species range; one concentrated in the south (U.S. West coast), one at Brookings, Oregon, and one that is concentrated in Western Alaska (Hess et al., 2022) The 2003 assessment of black rockfish considered the population in California and Oregon as a population unit (Ralston and Dick, 2003). In contrast, the 1999 and 2007 assessments modeled two separate populations north and south of Cape Falcon (Wallace et al., 1999; 2008). However, research conducted by Baker (1999) concluded that black rockfish from north and south of Cape Falcon (45°46' N. lat.) were genetically very similar.

Distance of larval dispersal of black rockfish appears to be limited (Miller and Shanks, 2004; Lotterhos et al., 2014) and may be a result of oceanographic conditions on the U.S. West coast (Strub et al., 1987; Miller and Shanks, 2004). Larvae and pelagic juveniles are associated with upwelling fronts but are also found landward and seaward of such oceanographic fronts (Larson et al., 1994, Sakuma et al. 2013). Parturition of larvae occurs during winter (Wyllie-Echeverria, 1987) and larvae and small juveniles are pelagic for several months before settling to kelp forest or other nearshore habitats (Boehlert and Yoklavich, 1983, Laidig et al., 2007). The abundance of pelagic juveniles of black rockfish and most other winter-spawning species is highly variable in time and space, and generally covaries among species and in response to large-scale oceanographic conditions associated with transport and source waters in the California Current (Ralston et al., 2013; Schroeder et al., 2019; Field et al., 2021).

Black rockfish off the northern Washington coast and outer Strait of Juan de Fuca exhibit no significant movement. However, fish appear to move from the central Washington coast southward to the Columbia River, but not into waters off Oregon. Movement displayed by black rockfish off the northern Oregon coast is primarily northward to the Columbia River (Culver 1987). Black rockfish form mixed sex, midwater schools, especially in shallow water (Hart, 1988; Stein and Hassler, 1989).

Tagging studies have documented some individuals moving several hundreds of miles, yet the majority of recaptured individuals were found relatively close to the areas of initial capture and tagging (Culver, 1987; Ayres, 1988; Starr and Green, 2007; Wallace et al., 2010; Friewald 2012). Acoustic tagging studies off Oregon noted tagged fish had relatively small home ranges that did not vary seasonally (Parker et al., 2007). Green and Starr (2011) report similar findings from a study in Carmel Bay, California of 23 acoustically tagged black rockfish, finding that approximately two-thirds of their tagged fish demonstrated small home ranges, although the remaining third (9 of 23 fish) appeared to leave the study area within six months of release. A more recent extensive tagging effort in Central California over the last 15 years suggests somewhat higher movement rates for black rockfish in California waters, in which over a dozen tagged individuals (out of 61 recaptures) moved hundreds of kilometers (the average movement rate was 168 km), with all extensive movements being to northern California or Oregon (Hamilton et al., 2021).

Black rockfish was last assessed in 2015 by three assessment stratifications (California, Oregon, Washington). The SSC and NMFS endorsed the California, Oregon, and Washington 2015 black rockfish assessments as BSIA ([Agenda Item I.3.a, Supplemental SSC Report 1, November 2015](#)). Although both the California and Washington assessment models estimated recruitment deviations and recruitment, the Oregon model did not, thus an evaluation of similarities in recruitment among the three models (which might be suggestive of population connectivity and structure) is not feasible with current information. Black rockfish is being reassessed for 2023. Black rockfish is currently managed as individual species in California and Washington; whereas, in Oregon it is currently managed within the black/blue/deacon rockfish complex.

Canary rockfish

Canary rockfish (*Sebastes pinniger*) are distributed in the northeastern Pacific Ocean from the western Gulf of Alaska to northern Baja California; however, the species is most abundant from British Columbia to central California (Miller and Lea, 1972; Love et al., 2002).

Little direct information exists regarding the population structure of canary rockfish off the U.S. West coast. Previous genetic analysis of population structure conducted by Wishard et al. (1980) found patterns that suggest two stocks may exist for canary rockfish – one located off northern California and southern Oregon and the other located off northern Oregon and Washington. However, more recent work using microsatellite loci and restriction site associated DNA sequencing (RAD-seq), suggest little support for canary rockfish population structure along the U.S. West coast (Gomez-Uchida et al., 2003; Budrick, 2016; Andrews et al., 2018). Genetic studies in Puget Sound, Washington, similarly show no differentiation between Puget Sound and coastal populations (Andrews et al., 2018). In addition, isotopic analysis of canary rockfish otoliths did not show distinct differences indicating that canary rockfish in Washington and Oregon may belong to a single spawning stock (Gao et al., 2013).

Information about larval dispersal of canary rockfish is sparse. Canary rockfish spawn in the winter, producing pelagic larvae that remain in the upper water column for 3-4 months (Krigsman, 2000; Love et al., 2002). Juveniles settle in shallow water around nearshore rocky reefs, where they may congregate for up to three years (Boehlert, 1980; Sampson, 1996) before moving into deeper water as they increase in body size. Andrews et al. (2021) showed via simulation that canary rockfish larvae in Puget Sound could disperse more widely than yelloweye rockfish due to timing of spawning and extend across multiple basins and out to coastal areas.

Significant movement of adult canary rockfish was found in the few studies on the topic. Tagging research conducted off Oregon found that of 10 canary rockfish recovered, 4 moved over 25 km, and 3 moved more than 100 km over a period of several years (DeMott, 1982). A single canary from that study moved 326 km to the south, and those that moved the farthest also moved to much greater depths than the shallow reefs at which they had been tagged. Another tagging study conducted off Oregon concluded canary rockfish exhibit wide-ranging movements and showed low site fidelity, with movement extending beyond the spatial range of their study (Hannah and Rankin, 2011).

Canary rockfish show latitudinal patterns in life history parameters. Individuals sampled in non-trawlable areas from colder, northern port locations exhibited larger sizes-at-age, lived longer, had variable condition, matured at larger sizes and older ages, and had lower mortality rates than those from warmer, southern locations (Brooks, 2021). Keller et al. (2018) sampled canary rockfish using fishery-independent trawl gear and similarly found that weight relative to length for males and females, growth rates of females, and maximum size of males increased with latitude.

There are few biogeographic boundaries clearly applicable to rockfish on the U.S. and Canadian West coasts. Keller et al. (2018) assessed the spatial variability of life history parameters independently and used predetermined regions separated by prominent biogeographic breakpoints (Point Conception [34°27' N. lat.] and Cape Mendocino [40°30' N. lat.], California) along the U.S. West coast. Recent work by Brooks (2021) identified subpopulations based on similarities in life history traits among focal ports and found a break in the canary rockfish stock to occur just north of Cape Blanco (42°50' N. lat.), Oregon. Discrepancies of the breakpoints in the two studies could be a result of the differences in analytical techniques used to delineate subpopulations, and differences in the habitats sampled (Brooks, 2021).

Canary rockfish assessments have modeled the resource as a single coastwide population (Methot and Piner, 2002; Methot and Stewart, 2005; Stewart, 2009; Wallace and Cope, 2011; Thorson and Wetzel, 2016). The last [assessment in 2015](#) assumed a single coastwide stock but incorporated spatial structure within the model that corresponded to state boundaries to account for variation in exploitation history among regions (Thorson and Wetzel, 2016).

The SSC and NMFS endorsed the 2015 assessment as BSIA ([Agenda Item D.8.a, Supplemental SSC Report 1, June 2015](#)). Canary rockfish is being reassessed for 2023. Canary rockfish is currently managed as a single population coastwide.

Copper rockfish

Copper rockfish (*Sebastes caurinus*) are found from Mexico to Alaska as well as in Puget Sound, Washington. Information regarding population delineation for copper rockfish in the 2021 assessment was provided in [Agenda Item E.3, Attachment 5, November 2021](#), which is incorporated by reference.

Sivasundar and Palumbi (2010) measured moderate differentiation mtDNA structure but no nuclear structure in the coastal copper rockfish population. They noted the Oregon and Monterey Bay populations were both genetically differentiated from the Santa Barbara populations, but the Oregon and Monterey Bay populations could not be distinguished from each other (Sivasundar and Palumbi, 2010). This could indicate that there is some level of mixing between northern California and Oregon populations, while limited mixing within southern and northern California. Buonaccorsi et al. (2002) identified significant divergence along the U.S. West coast when measured as variance in allele frequency or mean repeat number, indicating a substantial isolation between regions. Johansson et al. (2008) had robust sample sizes for copper rockfish ranging from coastal Washington through San Diego, California, with most samples from coastal Oregon, and identified isolation by distance among these regions. Their results were consistent with some level of population structure at a finer than coastwide scale, with some indication that Cape Blanco (42°50' N. lat.) or other habitat features (including an extensive sand barrier separating rocky habitats) in southern Oregon as likely mechanisms for the greatest differences observed in their study. They specifically suggest that their results are consistent with mesoscale population structure in which populations are self-recruiting on a regional scale with limited external recruitment from adjacent habitats.

Copper rockfish are spring, rather than winter spawners, with a shorter larval duration relative to most winter spawners of about 1-2 months, and the juveniles settle on kelp or soft bottom habitats and move to rocky areas with perennial macrophytes as they grow (Haldorson and Richards, 1987). Mean larval dispersal in copper rockfish based on data from Buonaccorsi et al. (2002) and the Rousset (1997) analytical model were low (under 40 km), even when accounting for four orders of magnitude of variation in possible effective population size (Buonaccorsi et al., 2004, 2005). However, as noted in the Buonaccorsi et al. (2002) study, the extensive spacing between samples leaves the cause of population divergence essentially unresolved, due to the large number of confounding variables.

Adult copper rockfish exhibit high site fidelity and generally show low to moderate movement in their home range (Lea et al, 1999; Tolimieri et al, 2009; Reynolds et al., 2010). However, in Santa Barbara Channel, California, Lowe et al. (2009) found tagged individuals showed low degrees of

site fidelity, and both Hanan and Curry (2012) and Hamilton et al. (2022) saw movement of up to several hundred kilometers in a small number of copper rockfish tagged off southern and/or central California. Adult life history and morphological evidence suggest that realized gene flow among regions of the copper rockfish distribution may be restricted. Adults exhibit extremely limited migrations (a few kilometers) and are unlikely to leave the reef on which they have settled (e.g., Lea et al., 1999).

Copper rockfish was last assessed in 2021 as four assessment stratifications ([California south of Point Conception](#), [California north of Point Conception](#), [Oregon](#), [Washington](#)). The SSC and NMFS endorsed all four 2021 assessments of copper rockfish as BSIA ([Agenda Item C.6.a, Supplemental SSC Report, September 2021](#)). Only the portion of the copper rockfish population off California is being reassessed in 2023. Copper rockfish are considered a coastwide stock, due primarily to the lack of a stock definition. Copper rockfish are currently managed in the nearshore rockfish complex with two units, north and south of 40° 10' N. latitude.

Dover Sole

Dover sole (*Microstomus pacificus*) are distributed from the Navarin Canyon in the northwest Bering Sea and westernmost Aleutian Islands, Alaska to San Cristobal Bay, Baja California, Mexico (PFMC, 2022b).

Dover sole was assessed as a single stock in 2021 ([Wetzel and Berger, 2021](#)). The assessment stated that population structure is not well understood. However, adults display ontogenetic movement from shallow to deeper waters with some level of spatial aggregation by sex (e.g., larger older females found in deeper waters compared to males) and larvae have an extended pelagic phase, up to two years off the U.S. West coast (Pearcy et al., 1977; Markle et al., 1992; Butler et al., 1996). Notable differences in growth and maturity of Dover sole across the U.S. West coast have been noted by multiple studies (Brodziak and Mikus, 2000; Wetzel and Berger, 2021) with fish in Oregon and Washington maturing at earlier size and growing to larger sizes-at-age. The movement of Dover sole across the U.S. West coast is generally unknown. Recent analysis examining data collected during the summer and fall months indicated movement from shallow to deeper water and shifts in aggregations moving southward off the California coast and northward to areas off the Washington coast (Ono et al., 2016). However, historical tagging studies indicated only limited latitudinal movement of Dover sole (Westrheim et al., 1992). Genetic analysis sampling Dover sole at different sites ranging between southern California to the Gulf of Alaska indicated some level of potential clustering of genetically similar individuals (Stepien, 1999). Areas off the U.S. West coast have been observed to have aggregations of age-1 fish potentially indicating some population structure by age or size (Tolimieri et al., 2020), however, the overall connectivity of the population remains uncertain.

Dover sole was last assessed in [2021](#) as a single population. The SSC and NMFS endorsed this assessment as BSIA ([Agenda Item E.2.a, Supplemental SSC Report 1, November 2021](#)). Dover sole is currently managed as a single coastwide unit.

Lingcod

Lingcod (*Ophiodon elongatus*) ranges from Baja California, Mexico, to Kodiak Island in the Gulf of Alaska (PFMC, 2022b). Lingcod was assessed in 2021 (Johnson et al., 2021; Taylor et al.,

2021). The assessments assumed two distinct lingcod populations on the U.S West coast that are split at 40° 10' N. lat. based on the results of a genetic analysis (Longo et al., 2020). Longo et al. (2020) determined sufficient evidence for distinct north and south genetic clusters with the presence of admixed individuals (i.e., mixes of previously diverged or isolated genetic lineages) in the region of overlap. The general results of the occurrence of two distinct genetic clusters were contrary to previous genetic work using mitochondrial DNA that found no genetic differentiation in the lingcod population (Marko et al., 2007)

Lingcod larvae are epipelagic for approximately 90 days (Hart, 1988; Phillips and Barraclough, 1977; Cass et al., 1990). Young-of-the-year typically recruit to sandy, low-relief habitat near eelgrass or kelp beds, staying on soft bottom and move into rocky, high-relief substrate as they grow (Petrie and Ryer, 2006; Bassett et al., 2018). Adults are generally sedentary and exhibit high site fidelity (Greenley, 2009; Bishop et al., 2010; Stahl et al., 2014).

Genetic information corresponded with results from recent work demonstrating that lingcod growth, longevity, and timing at maturity exhibit a latitudinal gradient (Johnson et al., 2021; Taylor et al., 2021). Lingcod from higher latitudes are larger at age, live longer, and reach biological maturity at larger sizes compared to lingcod in southern regions (Richards, et al. 1990; Silberberg, et al., 2001; Johnson et al., 2021; Lam et al., 2021; Taylor et al., 2021). Individuals north of 40° 10' N. lat. generally grow faster, live longer, and mature at larger sizes. Outside of the spawning season, male and female lingcod are segregated by depth. Females tend to inhabit deeper offshore waters and males inhabit nearshore rocky reefs.

Lingcod was last assessed in 2021 by two area assessments ([north of 40° 10' N. lat.](#) and [south of 40° 10' N. lat.](#)) The SSC and NMFS endorsed the 2021 full assessments of northern and southern lingcod as BSIA ([Agenda Item C.6.a, Supplemental SSC Report, September 2021](#)). Currently, Lingcod has two management units, north and south of 40° 10' N. latitude.

Pacific spiny dogfish

Pacific spiny dogfish (*Squalus suckleyi*) occur from the Gulf of Alaska, with isolated individuals found in the Bering Sea, southward to San Martin Island, in southern Baja California (PFMC, 2022b). Pacific spiny dogfish was most recently assessed in 2021. The 2021 assessment, as well as the 2011 assessment, assumed Pacific spiny dogfish off the U.S. West coast, bounded by the U.S./Canada border and U.S./Mexico border, consist of a single coastwide stock whose dynamics are independent of Pacific spiny dogfish populations off Canada and Mexico ([Gertseva et al., 2021](#)). While there is limited information on population structure of Pacific spiny dogfish populations within U.S. and Canadian waters, some level of cross border movement is likely occurring based on historical studies examining movement and population connectivity.

A spatial population dynamics model (Taylor, 2008) which included these tagging data (along with much larger tagging experiments conducted in Canada and inside U.S. waters of Puget Sound), estimated movement rates of about 5% per year between the U.S. coastal sub-population of Pacific spiny dogfish and that found along the west coast of Vancouver Island in Canada. The model also estimated movement rates of less than 1% per year between Pacific spiny dogfish in the U.S. coastal subpopulation of Pacific spiny dogfish and that in the Puget Sound. Off the U.S. West coast high densities of Pacific spiny dogfish have been observed close to the U.S./Canada border near the mouth of the Strait of Juan de Fuca (Gertseva et al., 2021). Additionally, some

evidence exists of inshore versus offshore populations migratory behavior, though inshore migratory distance may be less than offshore populations (Brodeur et al., 2009).

Pacific spiny dogfish was last assessed in [2021](#) as a single population (Gertseva et al., 2021). The SSC and NMFS endorsed this assessment as BSIA ([Agenda Item E.2, Supplemental SSC Report 1, November 2021](#)). Pacific spiny dogfish is currently managed as a single coastwide unit.

Petrale Sole

Petrale sole (*Eopsetta jordani*) range from the western Gulf of Alaska to the Coronado Islands, northern Baja California (PFMC, 2022b). A full assessment for petrale sole was performed in 2013 (Haltuch et al., 2013), with two subsequent assessment updates conducted in 2015 (Stawitz, et al., 2015) and 2019 (Wetzel, 2019). These assessments assumed petrale sole off the U.S. West coast was a single population. There is strong evidence of a mixed population from tagging studies, a lack of genetic studies on population structure, and a lack of evidence for differences in growth, as well as confounding differences in data collection between Washington, Oregon, and California (Haltuch et al., 2013).

Petrale sole have pelagic larvae and, after hatching, the larvae rise to the upper 50 m of the water column and remain there for approximately 5 months, through the feeding larval stage (Alderdice and Forrester, 1971; Casillas et al., 1998; Hart, 1973; Love, 1996; Percy et al., 1977). Planktonic petrale sole larvae range in size from approximately 3-20 mm and were found up to 150 km offshore foraging upon copepod eggs and nauplii (Casillas et al., 1998; Hart, 1988; MBC Applied Environmental Sciences, 1987; Moser, 1996) and juveniles show little coastwide or bathymetric movement. Studies suggest that adults generally move inshore and northward onto the continental shelf during the spring and summer to feeding grounds and offshore and southward during the fall and winter to deep water spawning grounds (Hart, 1988; MBC, 1987; Love, 1996). Adult petrale sole are highly mobile and have been observed to move up to 350-390 miles (Alverson and Chatwin, 1957; MBC, 1987). Demographic differences, in the form of fecundity, have been noted between fish off California and Oregon/Washington ([Lefebvre et al., 2019](#)).

The most recent full assessment for petrale sole was conducted in [2013](#) as a single population. The SSC and NMFS endorsed the full assessment as well as the subsequent [2015](#) and [2019](#) update assessments as BSIA ([Agenda Item F.5.b, Supplemental SSC Report, June 2013](#)). It is being reassessed for 2023. Petrale sole is currently managed as a single population.

Quillback rockfish

Quillback rockfish (*Sebastes maliger*) are found from southern California to the Gulf of Alaska (Love, et al., 2002). Information regarding population delineation for quillback rockfish in the 2021 assessment was provided in [Agenda Item E.3, Attachment 6, November 2021](#), which is incorporated by reference.

There has been limited genetic work on coastal populations of quillback rockfish. High site-fidelity (Hannah and Rankin, 2011) and relatively small home ranges (Tolimieri et al., 2009) for quillback rockfish suggest patterns of isolation-by-distance as found for other rockfish. However, localized studies within the Puget Sound, Washington area have shown significant genetic differences between Puget Sound and coastal stocks of quillback rockfish. However, there was no significant

differentiation in populations of quillback rockfish between coastal Washington and Alaska (Seeb, 1998; Stout et al., 2001; Schwenke et al., 2018).

Larvae are extruded from March through June (Love et al., 2002), and pelagic larvae and juveniles spend ~1–2 months in the upper water column before recruiting to nearshore benthic habitats. In Oregon, juveniles typically settle from June through August, but can settle as early as May and as late as September (Ottmann et al., 2018; Fennie et al., 2020).

Quillback rockfish exhibit long periods of residency with limited movements. In a tagging study in Puget Sound, Washington, which included quillback rockfish, Matthews (1990a; 1990b) found quillback rockfish had home ranges between 30m² to 1,500m². Home ranges on low relief reefs were greater than home ranges on high relief reefs (Matthews, 1990). Tolimieri et al. (2009) also found that home ranges of quillback rockfish in Puget Sound, Washington were relatively small (~1,500m² to ~2,500m²). However, it is important to note that movement of fish in the Puget Sound may not be representative of movement in coastal populations (Langseth et al., 2021). Rankin et al. (2013) observed larger home ranges of quillback rockfish at Cape Perpetua Reef, Oregon of approximately 1,200m² to 8,000m² for most individuals, with one quillback rockfish extending out to 24,000m². Lea et al. (1999) summarized tagging data from Morro to Monterey Bays, California that reported species of the gopher complex (which includes quillback rockfish although no quillback rockfish data were provided) to have no movement and therefore considered very residential in California.

Limited differences are observed in growth based on the original age-length estimates between fish off the Oregon and Washington coast (Langseth et al., 2021). However, it is commonly observed that there are spatial gradients of growth along the U.S. West coast (Keller et al., 2012; 2018; Gertseva et al., 2017).

Quillback rockfish were last assessed in 2021 by three assessment stratifications ([California](#), [Oregon](#), [Washington](#)) and endorsed by the SSC and NMFS as BSIA ([Agenda Item C.6.a, Supplemental SSC Report, September 2021](#)) Quillback rockfish is currently managed in the nearshore rockfish complex with two units, north and south of 40° 10' N. latitude.

Rex Sole

Rex sole (*Glyptocephalus zachirus*) ranges from central Baja California to the Aleutian Islands and the western Bering Sea (PFMC, 2022b). Rex sole was last assessed in 2013 ([Cope et al., 2014](#)) and was assumed to be a single population coastwide. A search of available literature revealed little to no information about the population structure off of the U.S. West coast. Information from Alaska notes there are growth differences in Eastern Gulf of Alaska (GOA) relative to Western and Central GOA as well as marked difference in growth rates and size at maturity between Oregon and GOA stocks (Abookire, 2006). Larvae are distributed broadly over the shelf and slope and exhibit cross-shelf transport, moving to nearshore nursery areas where they remain as juveniles (Abookire and Bailey, 2007; Bailey et al., 2008). Larvae attain a large size and have long pelagic lives, suggesting wide distribution by oceanic currents (Percy et al., 1977; Abookire and Bailey, 2007).

Rex sole was last assessed in [2013](#) as a single population. The SSC and NMFS endorsed the assessment as BSIA ([Agenda Item F.5.b, Supplemental SSC Report, June 2013](#)). It is being

reassessed for 2023. Rex sole is currently managed on a coastwide basis within the Other Flatfish Complex.

Sablefish

Sablefish, or also referred to as black cod, (*Anoplopoma fimbria*) are distributed in the northeastern Pacific Ocean from the southern tip of Baja California, northward to the north-central Bering Sea and in the Northwestern Pacific Ocean from Kamchatka, southward to the northeastern coast of Japan. Although few studies have critically evaluated issues regarding the population structure of this species, it appears there may exist at least three different stocks of sablefish along the West coast of North America: (1) a stock that exhibits relatively slow growth and small maximum size that is found south of Monterey Bay, California (Cailliet et al., 1988; Phillips and Inamura, 1954); (2) a stock that is characterized by moderately fast growth and large maximum size that occurs from northern California to Washington; and (3) a stock that grows very quickly and contains individuals that reach the largest maximum size of all sablefish in the northeastern Pacific Ocean, distributed off British Columbia, Canada and in the Gulf of Alaska (Mason et al., 1983; McFarlane and Beamish, 1983).

Spawning occurs annually in the late fall through winter in waters greater than 300 m (Hart, 1988; NOAA, 1990). Sablefish are oviparous with external fertilization (NOAA, 1990). Eggs hatch in about 15 days (Mason et al., 1983; NOAA, 1990) and are demersal until the yolk sac is absorbed (Mason et al., 1983). Age-zero juveniles become pelagic after the yolk sac is absorbed. Older juveniles and adults are benthopelagic. Larvae and small juveniles move inshore after spawning and may rear for up to four years (Boehlert and Yoklavich, 1985; Mason et al., 1983). Older juveniles and adults inhabit progressively deeper waters.

Sablefish was last assessed in [2021](#) as a single area (coastwide) population. The SSC and NMFS endorsed the assessment as BSIA ([Agenda Item C.6.a, Supplemental SSC Report, September 2021](#)). Currently, sablefish has two management units, north and south of 36° N. latitude.

Shortspine thornyhead

Shortspine thornyhead (*Sebastolobus alascanus*) are found in waters off the U.S. West coast from northern Baja California to the Bering Sea (PFMC, 2022b). Shortspine thornyhead were assessed in 2014 and are considered one homogeneous population, though apportioned at Point Conception (34°27' N. lat.), California for management purposes (Taylor and Stephens, 2014). Genetic studies of population structure do not suggest separate stocks along the U.S. West coast (Siebenaller, 1978). Stepien (1995) found few genetic differences among shortspine thornyhead along the Pacific coast but suggested there may be a separate population of shortspine thornyhead in the isolated area around Cortes Bank off San Diego, California. There are signals of genetic divergence between Alaska to southern California, but this seems to be more related to geographic distance rather than distinct population signals (Stepien et al., 2000; Taylor and Stephens, 2014).

Shortspine thornyhead along the U.S. West coast spawn pelagic, gelatinous masses between December and May (Wakefield, 1990; Erickson and Pikitch, 1993; Pearson and Gunderson, 2003). The larval and juvenile stages are pelagic and can last up to 15 months and adults are benthic (Moser, 1974; Wakefield, 1990; Wakefield and Smith, 1990; Dorval et al., 2022). Juveniles migrate down the slope with age and size to the oxygen minimum zone (Taylor and Stephens,

2014). Size distribution patterns have been consistently observed from survey data and have been conceptualized as a ‘J-shape’ migration hypothesis (Piner and Methot, 2001; Taylor and Stephens, 2014; Dorval et al., 2022). Stepien (1995) suggested juvenile dispersion might be limited in the area where the Alaska and California currents split. This occurs towards the northern boundary of the assessment area, near 48° N. latitude.

Shortspine thornyhead do not appear to be distributed evenly across the U.S. West coast, with higher densities of thornyheads in shallower areas (under 500 meters) off of Oregon and Washington, and higher densities in deeper areas off of California (Wakefield, 1990). The ontogeny and behavior of shortspine thornyhead are not conducive to large-scale latitudinal migrations, but these life history aspects cannot fully explain either the current distributional patterns (Dorval et al., 2022). Large mature fish reside mostly off central–northern California and oceanic currents could have played a role in transporting their offspring back to northern habitats (i.e., Washington and Oregon), where juveniles and young-of-the-year are most abundant. Otolith chemistry shows two distinct settlement regions of immature fish: one off the Columbia River plume expanding south to northern California and another off central and southern California (Dorval et al., 2022), which is consistent with the predicted ontogenetic movement (Jacobson and Vetter, 1996) as well as the pelagic life phase of larvae and early juveniles (Moser 1974; Wakefield, 1990).

The most recent shortspine thornyhead assessment was conducted in 2013 (document finalized in [2014](#)) as a single coastwide population. The SSC and NMFS endorsed the shortspine thornyhead assessment as BSIA ([Agenda Item F.5.b, Supplemental SSC Report, June 2013](#)). It is being reassessed for 2023. Shortspine thornyhead currently has a single ACL control rule with apportioned ACLs north and south of 34° 27' N. lat north and south of 34° 27' N. lat.

Squarespot rockfish

Squarespot rockfish (*Sebastes hopkinsi*) are found from southern Oregon to central Baja California (Love et al, 2002). This species was first assessed in 2021 (Cope et al., 2021). It is a relatively small rockfish found from Mexico to southern Oregon, with a core distribution in southern California. Squarespot rockfish were treated as one population in the most recent assessment due to their limited population distribution combined with the current lack of evidence of population structure off the U.S. West coast (Cope et al., 2021). Similar to many other rockfish species, squarespot rockfish exhibit sexual dimorphism, with females reaching larger sizes compared to males (PFMC, 2022b). Squarespot rockfish bear live planktonic larvae and can be found in the water column for up to 100 days post parturition (Taylor, 2004). A search of the literature revealed little life history information regarding this species. Squarespot rockfish are predominantly located south of 40° 10' N. latitude. Since 1981, approximately 99.73 percent of the total catch has occurred south of 40° 10' N. latitude off the U.S. West coast (Cope et al., 2021).

Squarespot rockfish was most recently assessed in [2021](#) off of California. The SSC and NMFS endorsed the 2021 squarespot rockfish assessment as BSIA ([Agenda Item C.6.a, Supplemental SSC Report, September 2021](#)). Squarespot rockfish is currently managed in the shelf rockfish complex with two units, north and south of 40° 10' N. latitude.

Vermilion and Vermilion/Sunset rockfish

Vermilion rockfish (*Sebastes miniatus*) was originally considered a single species; however, Hyde et al. (2008) determined it is actually a pair of cryptic species, vermilion rockfish and sunset rockfish (*Sebastes crocotulus*). Vermilion rockfish range from Prince William Sound, Alaska, to central Islas San Benito, Baja California at depths of 6 m to 436 m (Love et al., 2002). Vermilion and sunset rockfishes have a high degree of range overlap from central California to northern Baja, Mexico. However, vermilion rockfish are more common in shallower waters (< 100 m) in kelp forest habitat while sunset rockfish are typically found deeper (> 100 m) at offshore banks (Hyde et al., 2008a; 2008b; Love and Passarelli, 2020; Longo et al., 2022). The primary biomass of sunset rockfish appears to be in the Southern California Bight, though their range does somewhat extend north of Point Conception, California (Hyde et al., 2008; Hyde and Vetter, 2009; Budrick, 2016; PFMC, 2022b). Vermilion rockfish are abundant at least from central Oregon south into Mexico (Hyde and Vetter, 2009). For purposes of management, this cryptic species pair are currently treated as a single species.

Studies indicate significant genetic heterogeneity in this complex, with notable genetic barriers at Point Conception, Cape Mendocino, Santa Monica Bay, and along the Washington coast (Matala et al., 2004; Buonaccorsi et al., 2004; 2005; Hyde and Vetter, 2009).

Larvae and juveniles may spend from a month to a year in the water column before recruiting to benthic habitat (Boehlert 1977; Love et al., 2002). This lengthy dispersal phases could allow for large-scale geographic transport (Parrish et al., 1981). However, fish with both high fecundity, such as rockfish, and lengthy periods of larval dispersal are expected to show a high degree of gene flow with little or no genetic differentiation between populations (Hyde and Vetter, 2007), which is not the case for vermilion/sunset rockfishes. Isolation by distance analyses suggested that larval dispersal is relatively small (Hyde and Vetter, 2009).

Vermilion rockfish appear to exhibit high site fidelity (Hartman, 1987; Lea et al., 1999; Hannah and Rankin, 2011), and low average larval dispersal distance (Hyde and Vetter, 2009). A study by Lowe et al. (2009) suggested vermilion rockfish may not have strong site fidelity but noted this finding may be a result of not considering the depth preferences of the two species.

Vermilion/Sunset rockfish were assessed in 2021 in four assessments: [California south of Pt. Conception \(Dick et al, 2021\)](#), [California north of Pt. Conception \(Monk et al, 2021\)](#), [Oregon \(Cope and Whitman, 2021\)](#), and [Washington \(Cope et al, 2021\)](#). This spatial structure reflects the distribution of this cryptic species complex. The assessments represent the aggregate population dynamics of the cryptic species pair vermilion rockfish and sunset rockfish. The SSC and NMFS endorsed each assessment as BSIA ([Agenda Item C.6.a, Supplemental SSC Report 1, November 2021](#)). At present, vermilion/sunset rockfish are managed within the shelf rockfish complex with two units, north and south of 40° 10' N. latitude.

Appendix B - Differential Harvest Control Rules

Under Alternative 1, the Council expressed interest regarding the implications of Alternative 1 on harvest specifications and management measures (see Motion language above). The motion (above) stated that under Alternative 1, that the Council would have the "...ability to apply **harvest control rules (HCR)** where separate assessments are used to assess sub-areas of the coast." This analysis interprets the phrase "apply harvest control rules" within the current FMP framework as a reference to the application of the methods used to calculate harvest specifications that achieve optimum yield, including scientific uncertainty (sigma [σ]) and management risk tolerance (P*), and ACL control rules (e.g., 40-10 adjustment, etc.).

As stated in [H.5, Attachment 1](#), November 2022:

"The MSA, National Standards, and [FMP](#) contemplate rebuilding for a defined stock (or stock complex) and not sub-stocks. ...The primary relationship between HCRs and the purpose and need for Amendment 31 is the HCR that meets the obligations of a rebuilding plan for an overfished stock. Because of the strong linkage between the definition of the stock, the potential rebuilding plan, and the default HCR, ...HCRs should be set at the stock level (and not the sub-stock level)."

Calculating an ACL for a portion of a stock is inconsistent with the definition of ACL (at [§600.310\(f\)\(1\)\(iii\)](#)) and does not align with the harvest specifications framework in the FMP that contemplates a linear path from OFL to ABC to ACL. Presuming the harvest specifications framework in our FMP is consistent with NS1, the FMPs ACL control rules should be used to establish a catch level for a stock or stock complex based on BSIA. Council direction and guidance is requested to clarify the goals and objectives for this part of the motion.

Harvest Control Rule (HCR): In the FMP, HCRs are generally qualified by another term such as the MSY control rule, ABC control rule, etc. This analysis considers an HCR to follow the basic tenet that, in general, a HCR provides the scientific basis behind the rules used to set catch limits and is formed around management objectives and the data available on which to base scientific management advice (Punt, 2010). HCRs "...identify a pre-agreed course of management action as a function of identified stock status and other economic or environmental conditions, relative to agreed reference points" (Berger et al., 2012). A more common way to express what a harvest control rule is that it is a mechanism that sets catch at a point that addresses assessment uncertainty and Council risk concerns designed to achieve Council fishery objectives. The Council uses HCRs to calculate such management goals as the ABCs and ACLs for stocks and stock complexes in a manner that allows optimum yield to be established (PFMCA, 2022). ABC is set below the OFL and is designed to account for uncertainty in the estimate of OFL. The OFL is reduced by the P*/ sigma approach to determine the ABC. These factors are used to buffer against exceeding the OFL based on the stock's assessment Category. The ACL is a harvest specification set at or below ABC and is intended to prevent overfishing (PFMC, 2022a).

The term “harvest control rule” does not appear in the MSA or the NS1 guidelines. The NS1 guidelines defines “ACL” and “control rule” as follows:

Annual catch limit (ACL) is a limit on the total annual catch of a stock or stock complex, which cannot exceed the ABC, that serves as the basis for invoking AMs. An ACL may be divided into sector-ACLs.

Control rule is a policy for establishing a limit or target catch level that is based on the best scientific information available and is established by the Council in consultation with its SSC.

As part of the discussions regarding this action, the Council stated it wants the flexibility to use differential HCRs in the assessed sub-areas to reflect a particular factor of the assessment result, e.g., biomass, spawning potential, etc. The methodology by which different harvest control rules would be applied for sub-area assessments of a stock defined at a larger geographic scale, while being consistent with the harvest specifications framework in the FMP, is unclear. To incorporate this Council motion, while maintaining alternatives that appear to be consistent with the harvest specifications framework in the FMP, analysts offer a sub-alternative specific to Alternative 1 for Council consideration.

Sub-alternative 1a is considered applicable to black, copper, quillback, and vermilion/sunset rockfishes as they are the only species that have separate assessments for sub-areas of the coast and are considered under Alternative 1. Under Alternative 1 and Sub-Alternative 1a, the presumption is these sub-area assessments would be pooled and the species designated a single stock within the FMU.

Sub-Alternative 1a: Single Stock, Multiple Assessment Areas, Multiple HCRs, Complexes

Sub-Alternative 1a reflects the Council’s requested structure for Alternative 1 in their motion for the ROA. Under Sub-Alternative 1a, black, copper, quillback, and vermilion/sunset rockfishes would each be defined as a single stock. However, portions of each stock would be managed under different HCRs (i.e., separate sub-area ACL calculations); presumably, those portions would align with the areas of current sub-area assessments. The HCRs would be based on Council policies related to management risk and uncertainty. Each assessed sub-area could have its own sigma/P* or ACL control rule applied, prior to the sub-areas being summed, to calculate the stock ABC/ACL or ABC/ACL contribution (Figure B 1). The single OFL/ABC/ACL could then be apportioned back to the coast at a specified geographic scale (e.g., north and south of 40° 10’ N. lat.) Such an **apportionment** could be formal or informal and should be developed with SSC, GMT, and GAP input if it differs from status quo. The process must be described in the FMP.

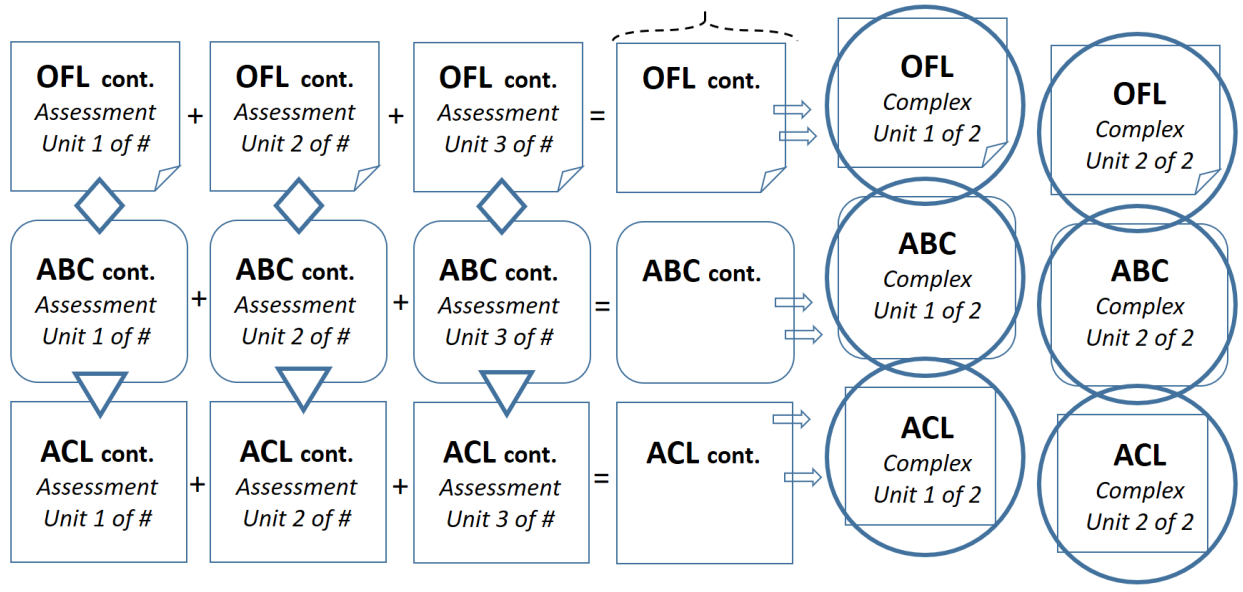

Figure B 1. Illustration of harvest specifications calculation methods (i.e., harvest control rules) for an example stock of rockfish with multiple assessment sub-area units and that is managed in a rockfish stock complex. The hashed bracket represents the stock for which overfished status would be determined under Alternative 1a, the diamond represents sigma/P*, triangle represents the ACL control rule, and arrows represent apportionments. Circles indicate values that are specified in regulations (for informational purposes). Left and center columns show contributions (cont.) for calculating harvest specifications.

Sub-Alternative 1b: 2- Single Stock, Multiple Assessment Areas, Single HCR, Complexes

Under Sub-Alternative 1b, the sub-areas are pooled to calculate a coastwide OFL/ABC/ACL (specifications). The ABCs are generated using a consistent P* and sigma could vary by sub-area assessment. The coastwide ACL is calculated using a single ACL control rule. These values are then apportioned to their regional complexes using previously used methods. The Council could also choose to establish sector-ACLs, using similar apportionment methods. While this method does not establish different ACL control rules, it does not prevent the Council from using precautionary management measures, as warranted, to meet management objectives in the FMP.

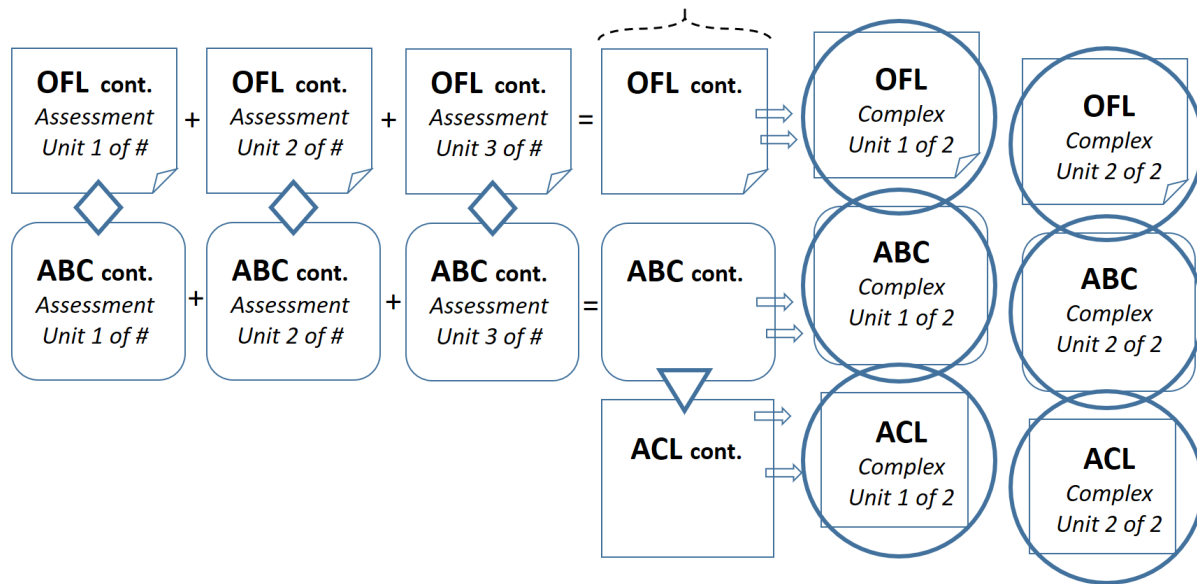

Figure B 2. Illustration of harvest specification methods for a priority species that is defined as a single stock with multiple assessment areas, managed as part of a stock complex, and the ACL contribution is calculated using a single ACL control rule for the stock. The diamond represents σ/P^* (where σ may vary by sub-area but P^* is constant among areas), triangle represents the ACL control rule, arrows represent regional apportionment, and large circles represent values that are specified in regulations. Left and center columns show contributions (cont.) for calculating harvest specifications.

Under current practice, black rockfish is managed in a complex off Oregon (OFL/ABC/ACL contributions) and with species-specific and state-specific OFLs/ABCs/ACLs off Washington and California, see above section (0) for further details.

Sub-Alternative 1a/b Analysis

As discussed above in Sub-Alternative 1a: Single Stock, Multiple Assessment Areas, Multiple HCRs, Complexes, black, copper, quillback, and vermilion/sunset rockfishes would each be defined as a single stock. However, portions of each stock would be managed under different HCRs (i.e., separate sub-area ACL calculations); presumably, those portions would align with the areas of current sub-area assessments. As discussed above in Sub-Alternative 1b: 2- Single Stock, Multiple Assessment Areas, Single HCR, Complexes, under Sub-Alternative 1b the ACL for the stock would be calculated using a single HCR for the stock (i.e., a single coastwide ACL calculation) that the Council deems is appropriate for a single stock. Under Sub-Alternative 1b, the Council could apportion the ACL into sector-ACLs if deemed desirable for management. It is impractical to quantitatively assess the ramifications of these sub-alternatives because each sub-area could have a variety of HCRs, so there would be too many combinations to calculate a resulting ACL for each stock. Therefore, the following provides a broad comparative overview of the two sub-alternatives to Alternative 1 (single stock).

For species with known population structure, both sub-alternatives 1a and 1b increase the risk of a localized depletion (compared to all other action alternatives) because accountability measures would not be required to address local abundance trends. Sub-alternative 1a would allow the Council to tailor HCRs to address localized depletion at the assessed sub-area through P^*/σ (OFL/ABC) and/or through an ACL control rule. The FMP does not currently have this harvest

specifications framework and it is not clear that this alternative would be consistent with NS1 (See Section 5.1. Alternative 1a may be a precedent-setting use of HCRs, as it has not been known to be used by any Regional Fishery Management Council before.

Sub-alternative 1b places limited requirements for the Council to address localized depletion with harvest specifications, because precautionary adjustments to ACLs could only be applied for the entire stock. This interpretation is most consistent with MSA, National Standards, and [Section 4.6.2 of the FMP](#). Alternative 1b could address localized depletion with local accountability measures, but such measures would not be required by the MSA, National Standards, or [Section 4.6.2 of the FMP](#). The Council could amend the harvest specifications framework to allow sector-ACLs, as envisioned in the NS1 guidelines, but such a framework still may not require the Council to address localized depletion with harvest specifications.

Sub-alternative 1a may result in similar ACL calculations at a coastwide scale as Alternative 1b, however under Sub-alternative 1a the Council may vary the precautionary adjustments from ABC to ACL at the sub-area assessment scale compared to Sub-alternative 1b. Sub-Alternative 1b is more consistent with the MSA, National Standards, and [Section 4.6.2 of the FMP](#), but could likewise diminish the Council's ability to prevent overfishing and achieve OY for species that have known population structure .

Both Sub-alternatives 1a and 1b may need formal or informal allocation decisions to be made during the 2025-26 harvest specifications and management measures, which could be potentially controversial, as with any allocative action. Both alternatives may create an increased burden to make fair and equitable allocations/apportionments among the states. For species that have not typically had coastwide management measures, this allocative burden could increase due to the difference between how the species is managed at present and these sub-alternatives.

It is likely, that apportioned ACLs or allocative management measures will be necessary to meet the goals and objectives of the FMP for species that show population structure but are defined as single stocks under either Alternative 1a or 1b.

Allocation Framework: The PCGFMP's allocation framework is described in section 6.2.3, relates to non-biological issues, and is designed to address certain social or economic issues in the fishery. If the Council desires to maintain existing (or establish new) area-specific or regional management measures that are not at the same spatial scale as the stock definition, the allocation framework may be triggered.

As an example, sablefish and shortspine thornyhead ACLs are currently apportioned, north/south of 36° N. lat. and north/south of 34° 27' N. lat., respectively (Figure B 3). Sablefish has a coastwide assessment, overfished status determination, and OFL/ABC. A coastwide ACL is calculated using a single ACL control rule. The coastwide ACL is then apportioned into sub-areas aligned with the sablefish allocation framework in the FMP (as established by [Amendments 14](#) and [20](#)). Apportionment calculations are based on the 2014-2018 species distribution model area biomass estimates using data from the NMFS NWFSC West Coast Groundfish Bottom Trawl survey. Also, each region has area-specific management measures.

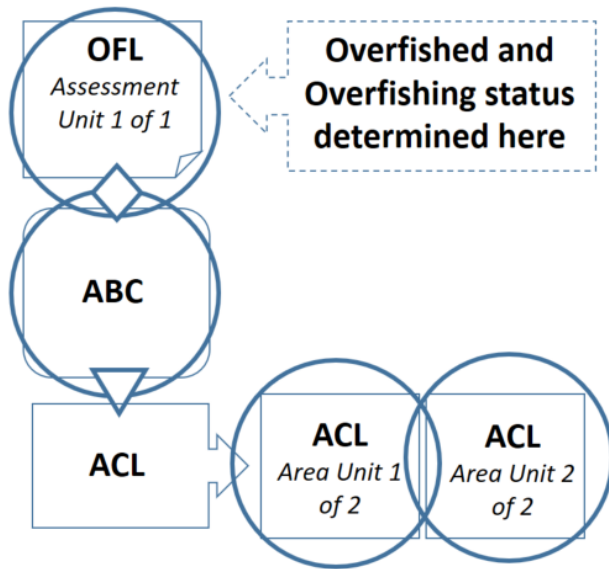

Figure B 3 Illustration of harvest specifications calculation methods (i.e., harvest control rules) applicable to sablefish, shortspine thornyhead, and longspine thornyhead. The diamond represents σ/P^* , triangle represents the ACL control rule, and arrows represent apportionment. Circles indicate values that are specified in regulations for informational purposes.

If, for example, black, copper, quillback, and vermilion/sunset rockfishes were defined as single stocks under either sub-alternative 1a or 1b, state-specific allocations would not stem from state-specific, SSC-recommended OFLs (as under Alternative 3). State-specific allocations would become allocative decisions, which must follow the FMPs allocation framework. If the Council wanted to relieve a recurring burden of discretionary state-specific allocations decisions for any of these species, formal allocations would need to be developed for the FMP.

Appendix C - Species with only one Alternative Considered

Eight of the priority species are considered under a single alternative: canary rockfish, Dover sole, lingcod, Pacific spiny dogfish, petrale sole, rex sole, sablefish, and shortspine thornyhead (Table C 1). The only comparative alternative to these species is the No Action Alternative, which, as discussed in Section 2.2, is untenable and not a meaningful comparison. Therefore, this analysis describes the impact of the alternative for each of those species but does not compare to other alternatives.

Table C 1. Eight priority species with only a single alternative considered for stock area delineation.

Priority Species	Alternative a/	Stock Area(s) Delineation
Canary rockfish	1	Single Stock
Dover sole	1	Single Stock
Pacific spiny dogfish	1	Single Stock
Petrале sole	1	Single Stock
Rex sole	1	Single Stock
Sablefish	1	Single Stock
Shortspine thornyhead	1	Single Stock
Lingcod	2	N. of 40° 10' N. lat. stock S. 40° 10' N. lat. stock

Canary rockfish, Dover sole, Pacific spiny dogfish, petrale sole, rex sole, sablefish, and shortspine thornyhead

Alternative 1 would define these priority species as single stocks with a geographic range set as the U.S. West Coast. A single stock definition is appropriate when sufficient mixing occurs and harvest in one area could affect the trajectory of the stock in all areas. Status for these stocks would be at the coastwide scale.

As described in Section 1.5, analysts provide a comparison of geographic extent of units used under four possible indicators. Canary rockfish, Dover sole, Pacific spiny dogfish, petrale sole, and rex sole have been consistently considered a single population across all metrics evaluated as shown in Table C 2 and detailed in Appendix A: Biological Information. Sablefish²⁹ and shortspine thornyhead³⁰ have also been considered a single populations across all metrics. The geographic scale for their ACL is less than coastwide, consistent with the geographic scale of their respective allocations in the FMP, however the ACL control rule that calculates their ACLs is applied

²⁹ For sablefish, a coastwide assessment is conducted. From the assessment, by application of the harvest specifications framework in the FMP, a coastwide ACL is calculated using a coastwide ACL control rule and then the ACL is apportioned north and south, so that formal allocation structures can be applied, consistent with the FMP.

³⁰ For shortspine thornyhead a coastwide assessment is conducted. In the 2023-24 groundfish harvest specifications and management measure process the coastwide ABC was apportioned N./S. of 34° 27' N. lat. and the ACL for each area was set equal to the ABC.

coastwide (i.e., two different ACL control rules are not applied to sub-areas independently). Sablefish ACLs and formal allocations are north and south (N./S.) of 36° N. lat. and shortspine thornyhead ACLs and formal allocations are N./S. of 34° 27' N. lat.

Table C 2. Comparison of annual catch limit (ACL) scale of species, NMFS status area, best scientific information available (BSIA) of population structure, and the most recent assessment, for species with only a single alternative (Alternative 1) considered (see Section 1.5).

Species	Geographic Factors of Population			
	ACL Scale	NMFS Status Area	BSIA Pop. structure	Assessment and Year
Canary Rockfish	Coastwide	Pacific Coast	Single Stock	Coastwide (2015) b/
Dover Sole	Coastwide	Pacific Coast	Single Stock	Coastwide (2021)
Pacific Spiny Dogfish	Coastwide	Pacific Coast	Single Stock	Coastwide (2021)
Petrale Sole	Coastwide	Pacific Coast	Single Stock	Coastwide (2019)
Rex Sole	Coastwide	Pacific Coast	Single Stock	Coastwide (2013) b/
Sablefish a/	North 36° N. lat.	Pacific Coast	Single Stock	Coastwide (2019)
	South 36° N. lat.			
Shortspine Thornyhead a/	North 34° 27' N. lat.	Pacific Coast	Single Stock	Coastwide (2013) b/
	South 34° 27' N. lat.			

a/ Geographic area of the ACL has been specified within the allocation framework of the FMP.

b/ Canary rockfish, rex sole, and shortspine thornyhead are to be reassessed in 2023.

A detailed literature review, assessment findings, and BSIA indicate these species have no discernible population structure along the coast. Genetics, larval dispersal, and/or adult movement data do not support, at present, delineating these species on a finer geographic scale than coastwide basis or as less than a single stock. All of these species have been assessed at the coastwide scale and have historically had single coastwide OFL/ABC/ACLs. The assessments were recommended by the SSC as BSIA, adopted by the Council,³¹ and determined as BSIA by NMFS. Further, the SSC recommended the geographic scale of each of these assessments as the scale for status determination³². Defining these species as stocks at a finer scale than coastwide would require new information. No new information was found in the literature review presented in Appendix 1. The Council could reconsider these definitions when that information is made available. An Alternative 1 stock definition for these species would be consistent with present harvest specifications and management measures. Alternative 1 is not likely to increase management burden or complexity as these species are managed on a coastwide basis at present. Multiple HCRs do not apply to these species based on current assessments, i.e., these assessments are for a single

³¹ See [Agenda Item G.5.a, Supplemental SSC Report 1, June 2021](#) for Dover sole and sablefish. See [Agenda Item D.8.a, Supplemental SSC Report 1, June 2015](#) for Canary rockfish; see [Agenda Item F.5.a, Supplemental SSC Report, June 2015](#) for rex sole; see [Agenda Item G.3.a, Supplemental SSC Report, Sept 2013](#) shortspine thornyhead; see [Agenda Item E.2.a, Supplemental SSC Report 1, November 2021](#) for Pacific spiny dogfish

³² *Id.*

area. For sablefish and shortspine thornyhead, if the current ACL apportionment process (e.g., as was done in the 2023-24 harvest specifications process) was followed with an Alternative 1 stock definition, it would be consistent with formal allocations in the FMP. Given the lack of evidence to support considering other alternatives for these species, no additional alternatives are considered, and no comparisons to the other alternatives can be made.

Lingcod

Lingcod is considered only under Alternative 2. This species is consistently stratified into two geographical regions across all metrics evaluated (Table C 3). Alternative 2 would define lingcod as two regional (N./S. of 40° 10' N. lat.) stocks with the OFL/ABC/ACLs set at that geographic scale. Lingcod has two distinct subpopulations along the coast (Longo et al., 2020), approximately one north and one south of 40° 10' N. lat. This biogeographic split was used as the basis for the most recent assessments (Johnson et al., 2021; Taylor et al., 2021). Available literature and assessment findings for lingcod supports the bi-regional stock definition. The SSC recommended the assessments as BSIA as well as the geographic scale for status determination ([Agenda Item C.6.a, Supplemental SSC Report 1, Sept. 2021](#)).

Table C 3. Comparison of annual catch limit (ACL) scale of species, NMFS status area, best scientific information available (BSIA), and the most recent assessment for lingcod.

Species	Geographic Factors of Population			
	ACL Scale	NMFS Status Area	BSIA Pop. structure	Assessment and Year
Lingcod	North 40° 10' N. lat.	N. Pacific Coast	North of 40° 10' N. lat.	North of 40° 10' N. lat. (2021)
	South 40° 10' N. lat.	S. Pacific Coast	South of 40° 10' N. lat.	South of 40° 10' N. lat. (2021)

Lingcod exhibit distinct population structure north and south of 40° 10' N. latitude. Lingcod harvest specifications and management measures have historically been set at those regional scales. Alternative 2 is consistent with current harvest specifications and management measures. Alternative 2 is not likely to increase management burden or complexity as lingcod is managed in this manner at present. Impacts of an Alternative 2 stock definition are expected to be consistent with the 2023-24 harvest specifications and management measures (PFMC, 2022a).

Given the lack of evidence to support considering other alternatives for these species, no additional alternatives are considered, and no comparisons to the other alternatives can be made.